



Model DS100S

Tripod Turnstile (Twin type)

DS100S Tripod Turnstile with twin rotating arms. Its main advantages:

- The twin type offers top security, preventing illegal tailgating by allowing only one person to pass at a time.
- Its 500mm+500mm dual arms, integrated in one cabinet increase passage efficiency. It handles two people simultaneously—whether entering or exiting—balancing safety and efficiency.
- The device boasts an elegant and grand design, integrating card-swipe functionality and featuring a stainless steel body for a sophisticated look.
- With a 520mm cabinet width, its robust structure fits all integrated solutions. Perfect for any location requiring sturdiness.

Features

- Two way or one way working.
- 304/316 stainless steel material.
- Support integrated with any type of access control systems.
- Lower power consumption.
- Low noise, system runs smoothly.
- Green and red LED indicator display passing status.
- Anti-tailing function: only one person passes at one time.
- Fire safety requirements, arms drop down automatically.
- Easy to install and maintain.
- 3 years warranty support.
-

Customized Service

- Appearance color can be customized based on installation environment.
- Dimensions can be customized to meet your request.
- Logo can be customized.
- Reader mount space can be customized.
- Waterproof outdoor can be customized.
- Picture: high resolution and 3D renderings pictures can be customized.
- The wireless remote control is available as a customized option, allowing front-desk staff to control the gate directly.



Logo Custom

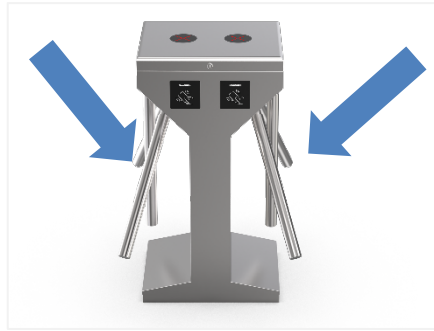

2 Arm Drop Down for Fire Safety Requirements

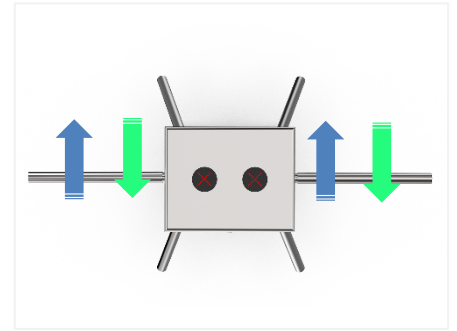

Single/Bi-directional



LED Indicator



Two-way Bi-directional Pass



Anti-tailing Function: one person can pass at one time

Access Control System

Daosafe turnstile gates can be well integrated with any 3rd party access control systems



Card Solution



QR/Bar Code Solution



Biometric Solution



Remote Control



Touchless Button



Card



QR Code



Fingerprint



Face





Palm Vein

Four lanes for card solution installed at building



Working with DSSP6002S Detachable Railing.

Specifications

Model No.	DS100S
Type	Tripod Turnstile (twin type)
Brand	Daosafe
Certifications	Compliance CE, ROHS, FCC
Framework Material	Stainless Steel
Arm material	Stainless Steel
Dimension	420(L) * 520(W) * 990(H)mm
Net Weight	60kg/pcs (double core)
Passage Width	550mm + 550mm (arm 500mm)
Passing Direction	Single directional/Bi-directional
MCBF	10 million
Power Supply	AC220V/110V, 50/60Hz
Operation Voltage	24V DC
Power Consumption	40W + 40W
Operation Temperature	-20 °C ~ 75 °C (can be customized)
Operation Humidity	0 ~ 95% (No freeze)
IP Level	IP54 (standard), IP65 (can be customized)
Working Environment	Indoor/Outdoor (can be customized)
Flow Rate	35 + 35 people per minute
LED Indicator (Top)	Constant Indicator Light:  Access Granted: 
Card Reader Mount	Under the top of the cabinet Max. dimensions: 100(L) * 100(W) * 25(T)mm (can be customized)
Emergency	Arm drop down automatic when power off
Communication	Dry contact, Relay signal, RS485
Flexibility	Integrate with any access control

Dimensions

Parameter	Standard	Recommended	Optional	Note
Arm Width	500mm	/	600mm (can be customized)	If need disabled lane, DSSP6003ABC or DS8000 are optional
One Arm	DS100 tripod turnstile is optional.			

Front View

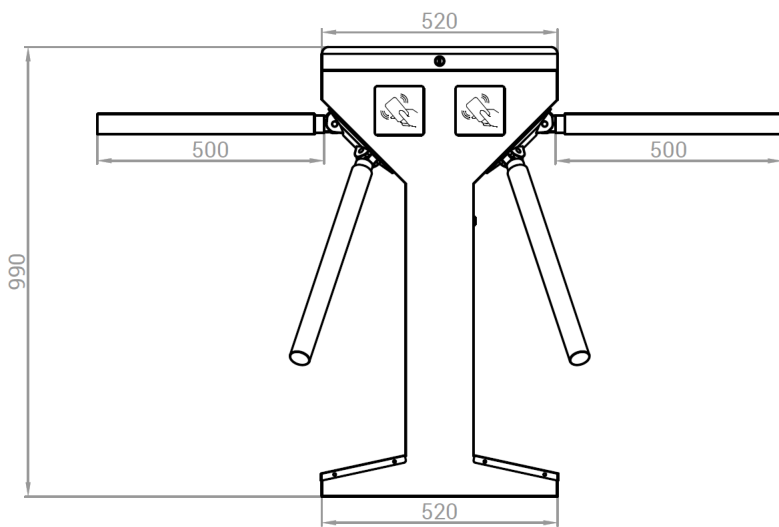

Side View

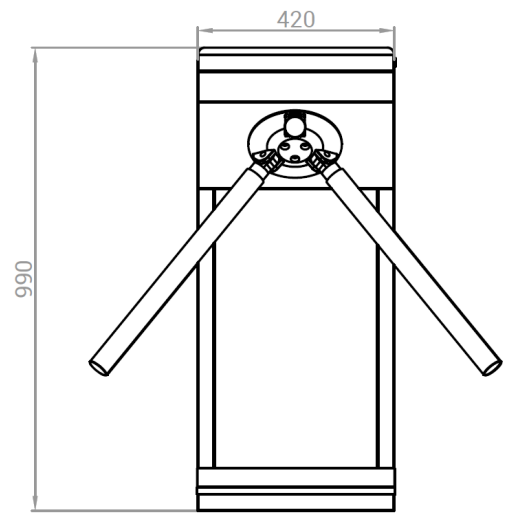

Top View

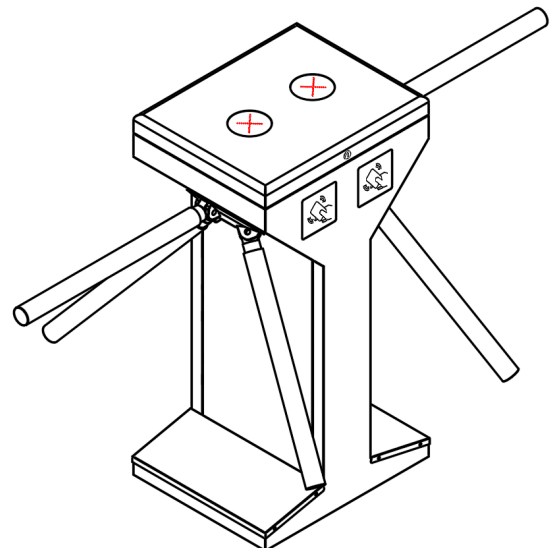
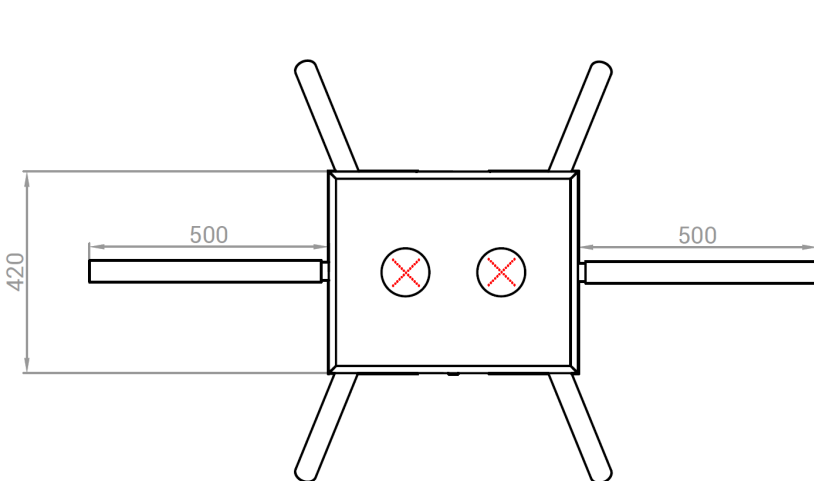

Six lanes for card processing have been installed in the Science Museum.



Working with DS8000
Cylinder Speed Gate.

The library has installed four lanes for card processing.

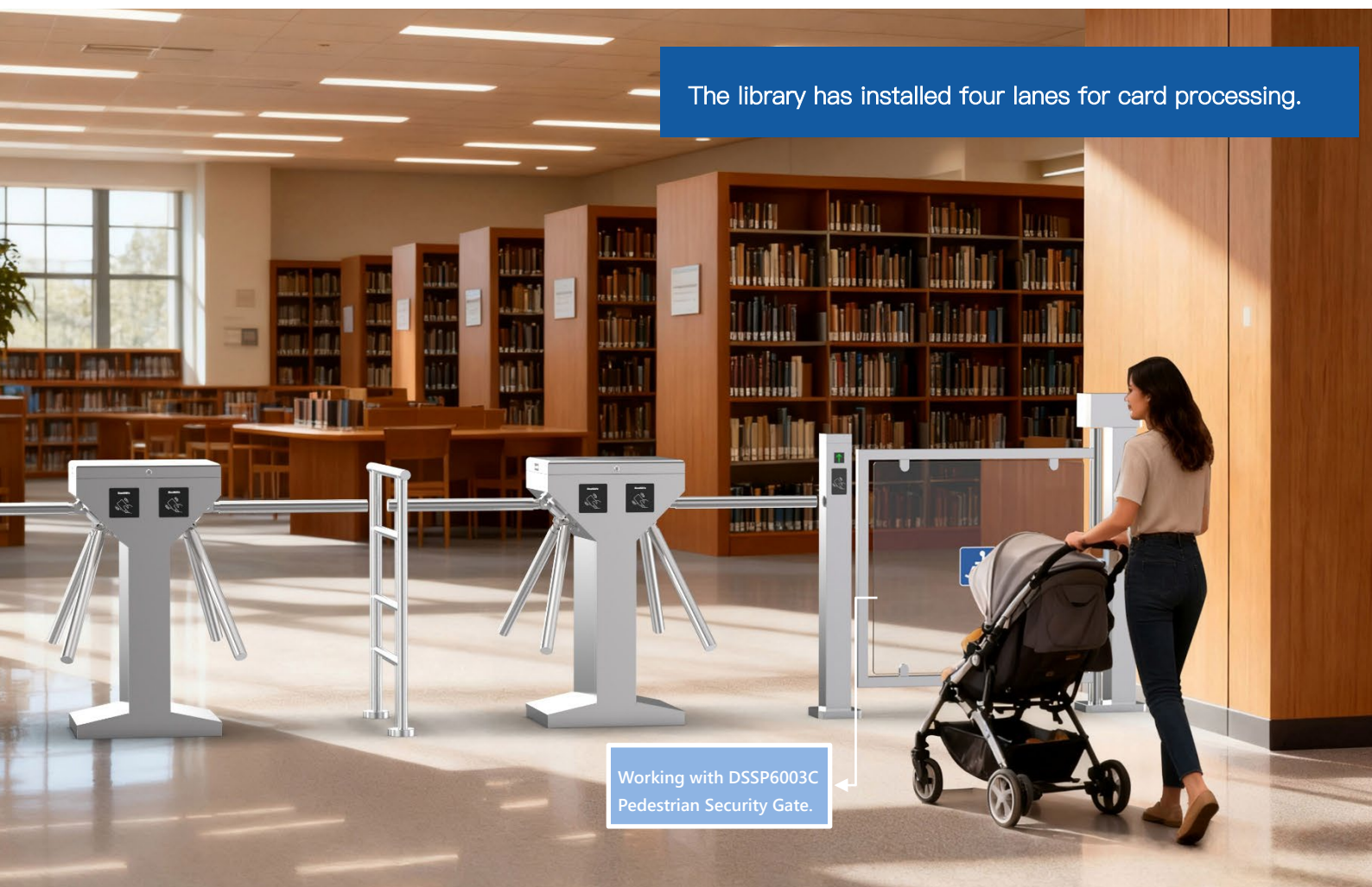

Working with DSSP6003C
Pedestrian Security Gate.