



Model DS205WL

Swing Turnstile Gate

DS205WL Cylinder Speed Gate is currently the most popular and classic type of swing gate, with the following major advantages:

- **Material:** The body is made of brushed stainless steel, which is robust, rigid, anti-rust, waterproof and durable.
- **Compact Size:** The cylindrical shape has a diameter of only 168mm, which does not require much space installed.
- **Electric Motor:** The motor enables the gate to work automatically.
- **Gate Arm:** It is made of a single piece of stainless steel from top to bottom, which makes it very safe.
- **Passage Width:** A single gate can have a maximum width of 900mm for wide passageways.
- **Top Light Strip:** The top is equipped with a 3-color light strip, allowing users to clearly see the passage status.
- **Anti-Pinch IR Sensors:** The columns are equipped with upper and lower anti-pinch IR sensors. The gate will not close if someone stands in the middle.
- **Options:** IR sensors or radar can be optionally installed on the front and rear of the columns to set the gate to open or close when people approach.
- **Wide application:** It is suitable for areas with general pedestrian traffic. (e.g.: Supermarket, Mall, Shop and so on)

Features

- Two way or one way working.
- Passage width: 1pcs support 600-900mm. 2pcs can support largest 1800mm width, which support 3-4 people entry at the same time.
- Low noise, system runs smoothly.
- Indoor use.
- Fire safety requirements, arm open automatically.
- Easy to install and maintain.
- 3 years warranty support.

Customized Service

- Appearance color can be customized based on installation environment.
- Dimensions can be customized to meet your request.
- Infrared sensor number optional.
- Logo can be customized.
- Picture: high resolution and 3D renderings pictures can be customized.
- Options: A wireless remote control is available as an option, allowing front-desk staff to control the gate directly.

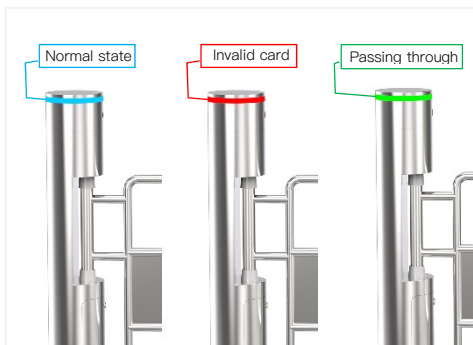

LED Light

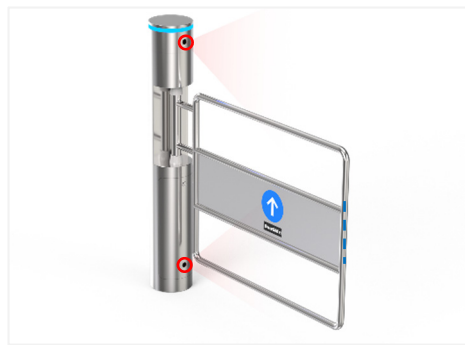

Infrared Anti-Pinch

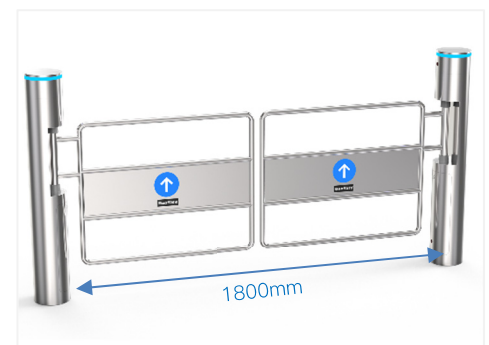

Double-Open Mode



168mm Slim Body

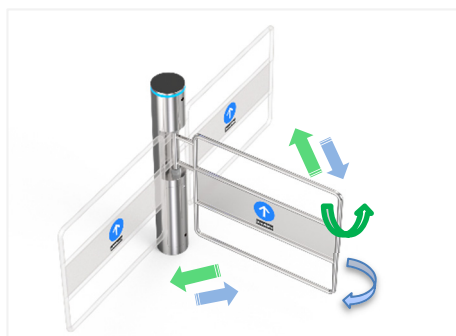

Left or Right Manual Push



Black Color Optional

Specifications

Model No.	DS205WL
Type	Swing Turnstile
Brand	Daosafe
Framework Material	Full stainless steel
Arm Material	Full stainless steel
Dimension	Framework: 168(Φ)*1075(H)mm Base: 168mm(Φ)
Net Weight	35kg/pcs
Passage Width	<ul style="list-style-type: none"> • One unit: 600mm (standard)~900mm (Maximum) • Two unit double open: 1200mm (standard)~1800mm (Maximum) • 900mm (recommended disabled lane)
Arm Height	835mm
MCBF	10million
Power Supply	AC220V/110V, 50/60Hz
Operation Voltage	24V DC
Power Consumption	40W
Operation Temperature	-20~75°C (can be customized)
Operation Humidity	0 ~ 95% (No freeze)
IP Level	IP54(standard)/IP65 (can be customized)
Working Environment	Indoor/Outdoor (can be customized)
Flow Rate	30 people per minute
LED Indicators (Strips)	Blue color: power on, green color: entry, red color: no entry
Passing Direction	Single directional/Bi-directional
Emergency	Automatic arm open when power off
Communication	Dry contact, Relay signal, RS485
Flexibility	Integrate with any access control

Dimensions

Parameter	Standard	Recommended (disabled)	Maximum	Note
Passage Width (one unit)	600mm	900mm	900mm	The arm cannot be too long to prevent the base from being unable to support it
Passage Width (Two units double open)	1200mm	/	1800mm	

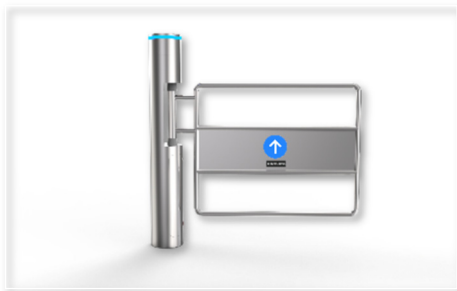
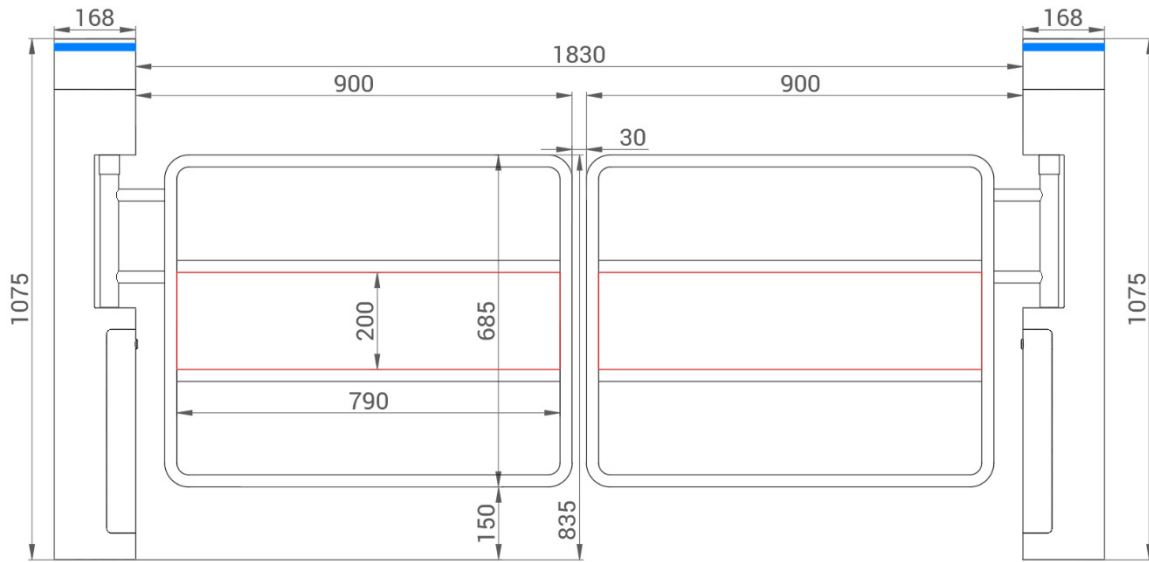
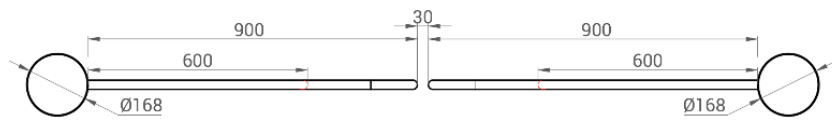
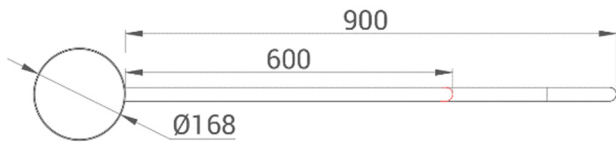
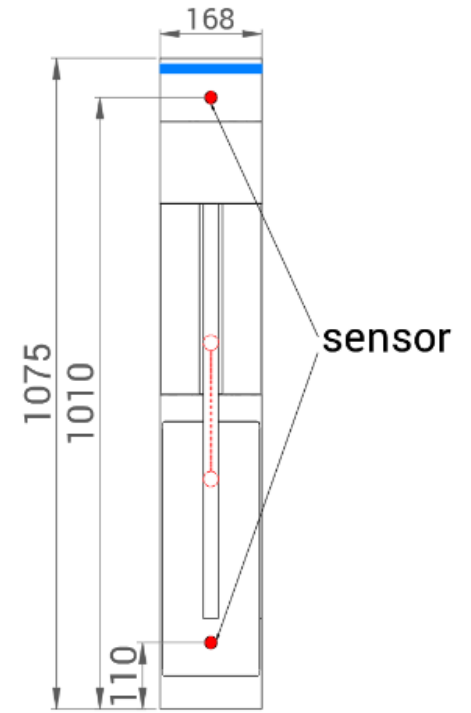
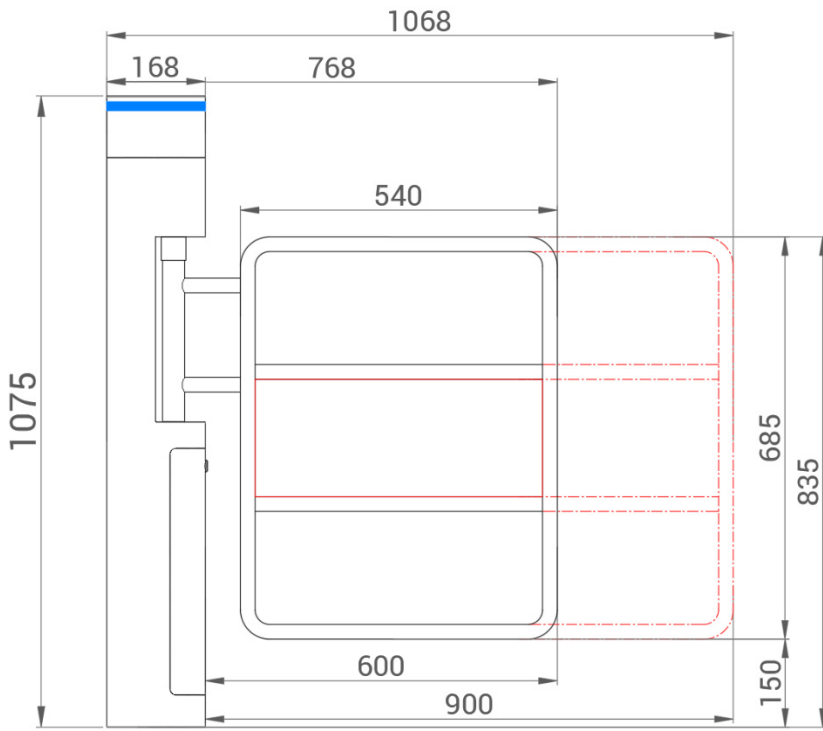

One Lane



Two Lanes



Two Units Double Open

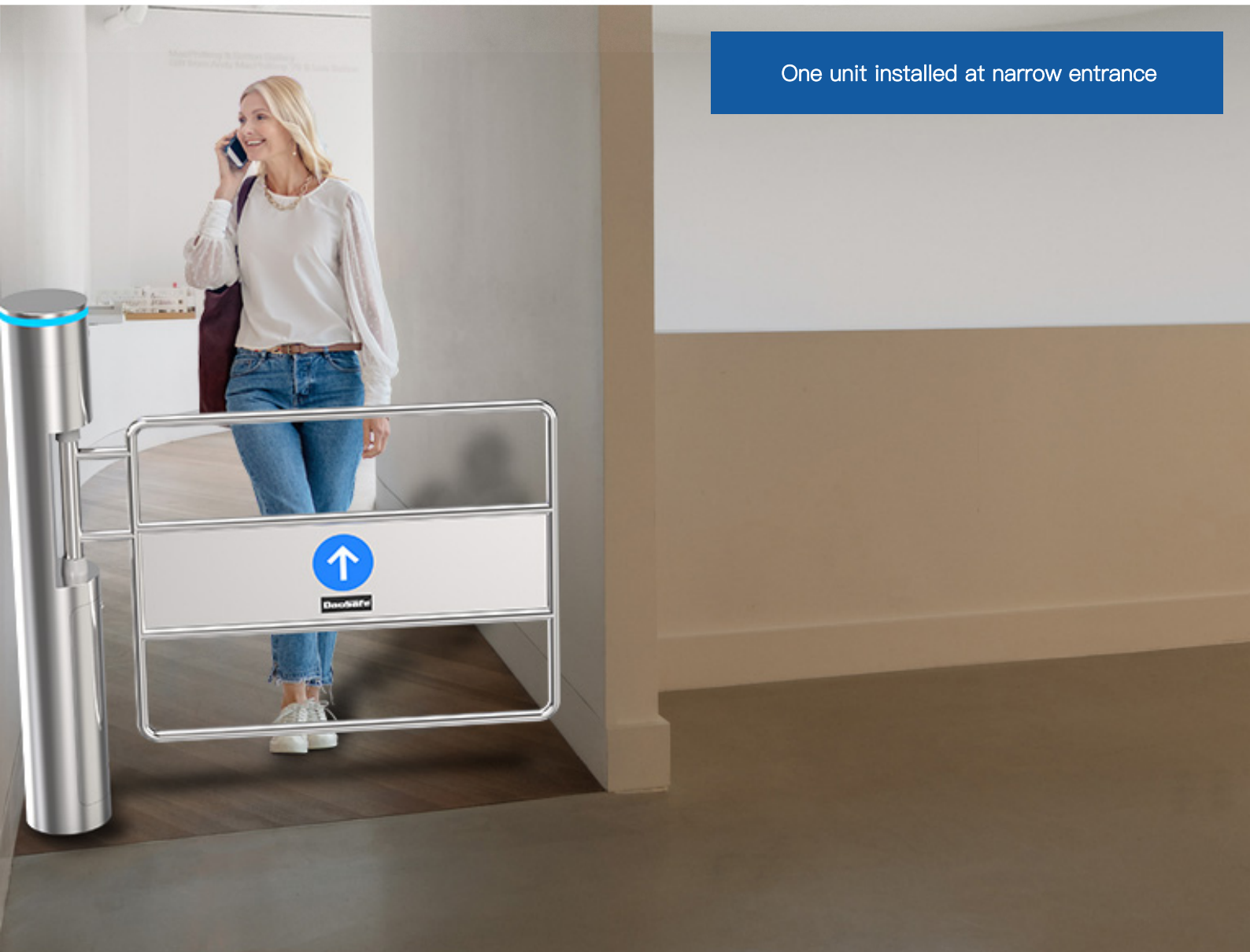

One unit installed at narrow entrance

One unit disabled lane installed at wide entrance



Two units double open mode installed at supermarket

