



## Model DS-Q50S

### QUANTUM Tripod Turnstile (Twin type)

QUANTUM DS-Q50S is a tripod turnstile with twin rotate arm, one cabinet with two 550mm passageways to improve traffic efficiency. Only one person can pass at one time, highest security to prevent the illegal trailing.

Design with classic black, white color appearance, elegant and timeless pairing, perfect for using at high end applications.

## Features

- Two way or one way working.
- Support integrated with any type of access control systems.
- 470\*400\*1000mm small size, fit for small installation space.
- Lower power consumption.
- Low noise, system runs smoothly.
- Green and red LED indicator display passing status.
- IP65 waterproof level, indoor/outdoor use.
- Fire safety requirements, arms drop down automatically.
- Easy to install and maintain.
- 3 years warranty support.

## Customized Service

- Appearance color can be customized based on installation environment.
- Dimensions can be customized to meet your request.
- Logo can be customized.
- Picture: high resolution and scene picture can be customized

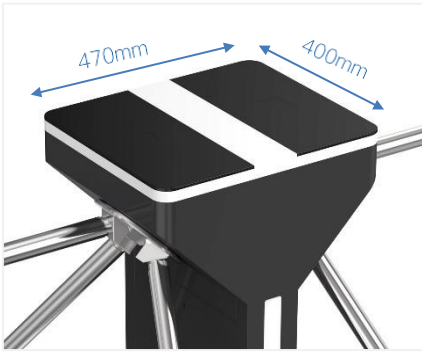

Small Size

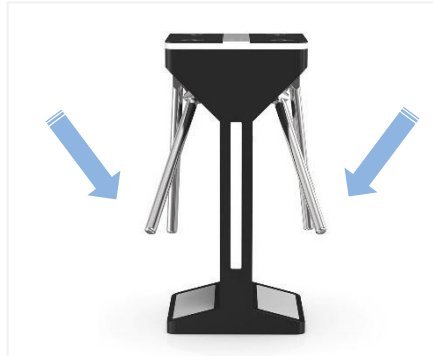

2 Arms Drop Down

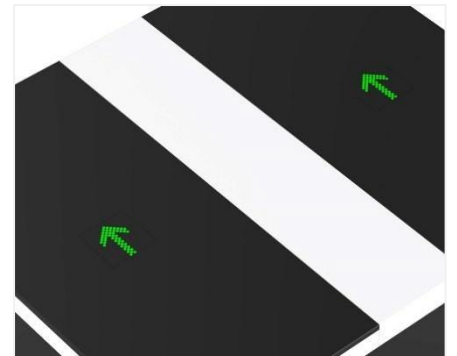

LED Indicator

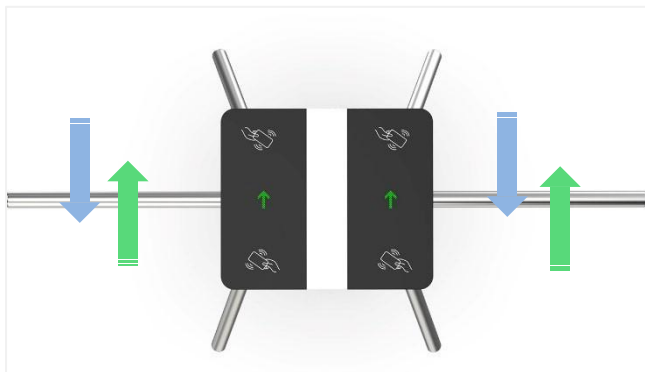

Single/Bi-directional Selectable



Anti-trailing Function: one person can pass at one time



Card Solution

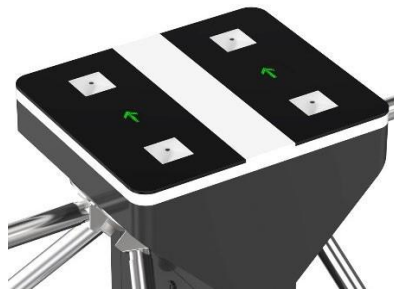

QR/Bar Code Solution



Biometric Solution



Remote Control



Touchless Button



Card



QR Code



Fingerprint



Face



Palm Vein

DS-Q50S with facial solution installed at office building



## Specifications

Model No.	DS-Q50S
Type	Quantum Tripod Turnstile
Brand	Daosafe
Certifications	Compliance CE, ROHS, FCC
Framework Material	Steel White and black stoving varnish Tempered glass
Arm material	Stainless Steel
Dimension	470 * 400 * 1000mm
Net Weight	60kg/pcs
Passage Width	550mm + 550mm
Passing Direction	Single directional / Bi-directional
MCBF	10 million
Power Supply	AC220V/110V, 50/60Hz
Operation Voltage	24V DC
Power Consumption	40W
Operation Temperature	-20 °C - 75 °C
Operation Humidity	0 ~ 95% (No freeze)
Working Environment	Indoor / Outdoor
Flow Rate	35+35 people per minute
LED Indicator	Two LED indicators on top: green → entry, red × no entry
Communication	Dry contact, Relay signal, RS485
Emergency	Arms will drop down automatically
Flexibility	Integrate with any access control

Side View

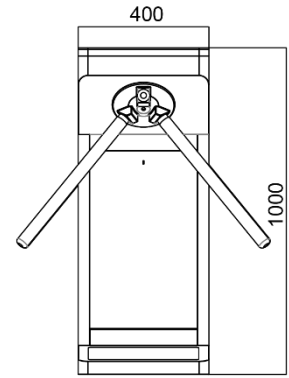

Front View

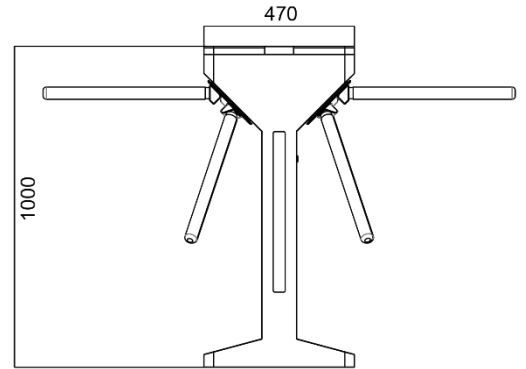

Top View

