



## Model DSSP6003B

### Pedestrian Security Gate (electromagnetic lock)

The DSSP6003B half-height pedestrian security gate is designed for individual operation or to integrate with a half-height turnstile for access control. It features a standard relay signal for compatibility with various third-party access control systems. This setup is a common and ideal solution for managing access for package deliveries, carts, handicapped individuals, and similar needs.

## Features

- The direction of door opening: one-way.
- 304 brushed stainless steel, durable and antirust.
- Support integrated with any type of access control systems.
- IP65 waterproof level, indoor/outdoor use.
- Fire safety requirements, arms open automatically.
- Easy to install and maintain.
- 3 years warranty support.

## Customized Service

- Material optional.
- Appearance color can be customized based on installation environment.
- Dimensions can be customized to meet your request.
- Logo can be customized.
- Picture: high resolution and scene picture can be customized

## Access Control System

Daosafe turnstile gates can be well integrated with any 3<sup>rd</sup> party access control systems



Card Solution



QR/Bar Code Solution



Remote Control



Touchless Button



Fingerprint



Face



Palm Vein



## Specifications

Model No.	DSSP6003B
Type	Electromagnetic lock
Brand	Daosafe
Framework Material	304 Stainless Steel + Plexiglass
Dimension	1200 * 170 * 1000mm
Net Weight	30kg/pcs
Passage Width	900mm
Passing Direction	Single directional / Bi-directional
Direction of Door Open	One way
MCBF	10 million
Power Supply	AC220V/110V, 50/60Hz
Operation Voltage	24V DC
Power Consumption	40W
Operation Temperature	-15 °C ~ 60 °C
Operation Humidity	0 ~ 95% (no freeze)
Working Environment	Indoor / outdoor
Flow Rate	30 people per minute
Communication	Dry contact, relay signal
Emergency	Arms will open when power off
Flexibility	Integrate with any access control

## Dimensions

Top View

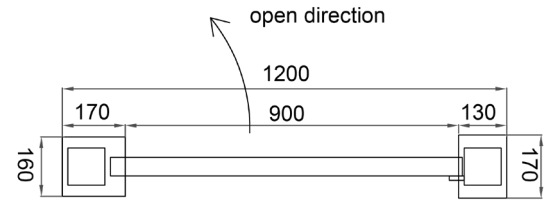



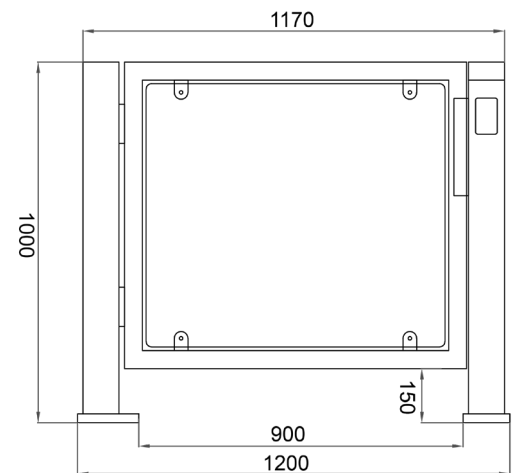

Front View



One way to open the door

## Comparison

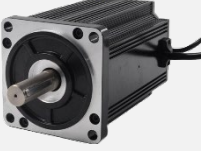
Model Photos			
Model DSSP6003.	A	B	C
Opening Mode	Manual type	Manual type	Automatic type
Direction of Door Opening	One way	One way	Two ways
Electric Lock	✗	✓	Motor with clutch
Access Control	✗	Support any access controllers	Support any access controllers
Power Supply	✗	✓	✓
LED Light	✗	✗	✓
Self Close	✗	✗	✓
Details	 key cylinder	 Magnetic lock	 Motor