



## DSN-80

### Nebula Speed Gate (High Glass)

#### Description

SAFETY  
LEVEL

AESTHETICS

COSTING

- Nebula high glass speed gate outstanding features: fast open and close speed, exceeding slim housing, different height glass arms.
- The glass arm can be heightened to 1400mm for high security control to prevent unauthorized person from climbing.
- The passing width can reach to 600mm for normal passage, and can support 900mm arm for wide passageway, wheelchair, and pedestrian with large luggage can also pass.
- It is ideal for both indoor or outdoor with waterproof design.
- Nebula speed gate high glass with unique design, stylish of modern and urbanization cabinet, tempered glass swipe card panel, attractive blue LED strip, solid body crate, high-end black painting process.
- Superior production: Integrated mold production to ensure the high quality guaranteed.
- Standard relay signal, which can be integrated with any kind of third-party access control system.
- In case of emergency, the arms will open automatically to allow free passage when power off.
- Application: suitable for any high-end sites, such as government building, chamber, bank, airport, stadium and so on.

We don't only offer turnstile gates

We offer full access control solutions



## Features

- ✓ Long-life performance, high operation dependability and fast response.
- ✓ Single directional or Bi-directional is selectable.
- ✓ Automatic reset function: swing arms will lock automatically within 5s (can be setting) if passenger delay to entry.
- ✓ When power is off, swing arms will open automatically, which is complying with fire safety requirements.
- ✓ LED indicator (red means no entry; green means entry; blue means normal close).
- ✓ Infrared sensor alarm function, in case of illegal intrusion and reverse intrusion.
- ✓ Anti-intrusion function, the speed gate is locked automatically until valid opening signal input.
- ✓ Anti-reverse function, the turnstile alarms if someone wants to entry in the reverse direction.
- ✓ Anti-trailing function, the speed gate alarms if someone wants to burst in without permission.
- ✓ Anti-collision and anti-kick function, it designed with consolidated and more durable mechanism, will not break even someone collide it.
- ✓ Mechanism self-protection: the arm will reset automatically if is off position. Its movement will not be broken or damaged even after hit.
- ✓ Easy to install and maintain.
- ✓ 3-year warranty support.



# Specification

Model No.	DSN-80
Type	Nebula Speed Gate (high glass)
Brand	Daosafe
Certification	Compliance CE, ROHS
Main Framework Material	Steel+ black stoving varnish
Swipe Card Panel Material	Tempered Glass
Arm Material	Plexiglas-transparency (standard) Tempered glass (optional)
Dimension	1400 * 185 * 990mm
Net Weight	60kg/pcs (single core), 75kg/pcs (double core)
Passage Width	600mm (standard), 900mm (handicap)
Arm Height	1200mm (standard), 900mm-1400mm (optional)
Waterproof	IP65
Passing Direction	Single directional / Bi-directional
MCBF	10 million
Power Supply	AC220V/110V, 50/60Hz
Operation Voltage	24V DC
Power Consumption	40-70W
Operation Temperature	-15 °C - 70 °C
Operation Humidity	0 ~ 95% (No freeze)
Working Environment	Indoor / Outdoor (shelter)
Flow Rate	35 people per minute
LED Indicator	Unique blue LED strip (front + top)
Infrared Sensor	6 pairs(standard)
Emergency	Automatic arm open when power off
Flexibility	Integrate with any access control
Communication	Dry contact, Relay signal, RS485

# Dimension

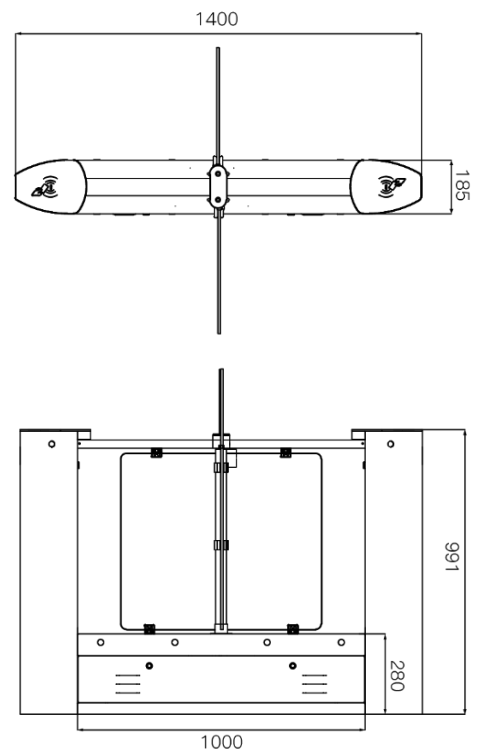
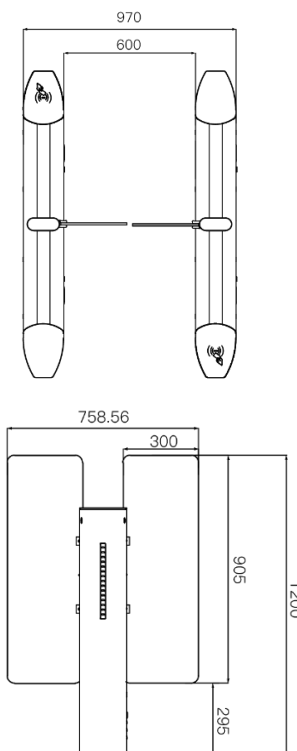
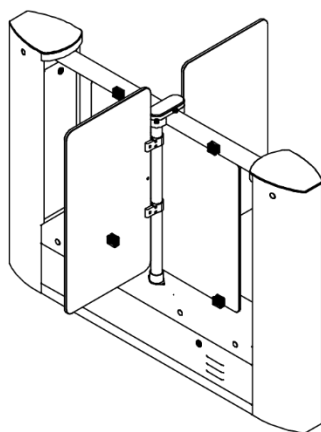

# DSN-80



The most special feature of Nebula speed gate high glass DSN-80 is the glass arm can be heightened to 900-1400mm (maximum) for high security control to prevent unauthorized person from climbing.



# System Integration Figure

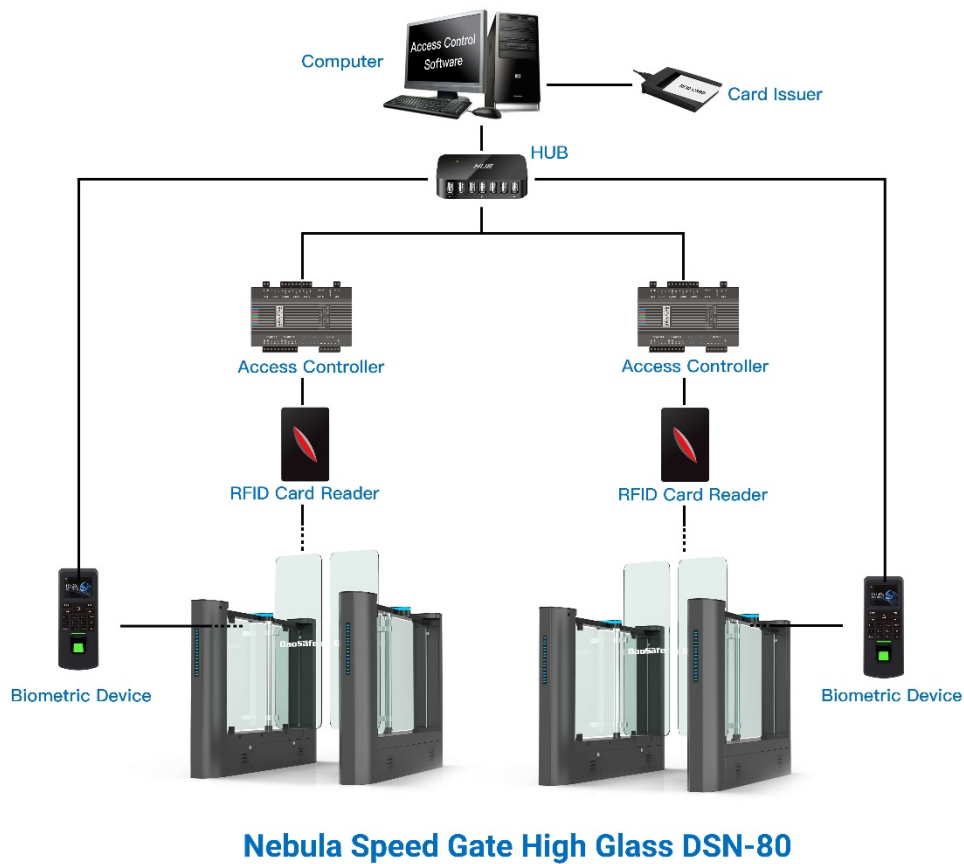

## REMARK:

- The turnstile circuit board support to work with any relay signal, and support to integrated with any 3rd party access control system: RFID, BIOMETRIC, QR/BARCODE and so on.
- Multiple access controller board can be connected by TCP/IP through net cable, control by central computer.
- The turnstile circuit board is also with RS232 output, it can connect with mini PC. Turnstile will open once received simple code by computer, which is suitable for the complicated like ticketing system solution.

Nebula high glass speed gate outstanding features: fast open and close speed, exceeding slim housing, different height glass arms.  
The width supports standard swing type 600mm and handicapped swing type 900mm for wide passageway.  
The height supports 900mm or 1200mm or 1400mm to prevent unauthorized person from climbing over.



Standard + Handicapped Lane



1200mm Height



1400mm Height

## Glass Height

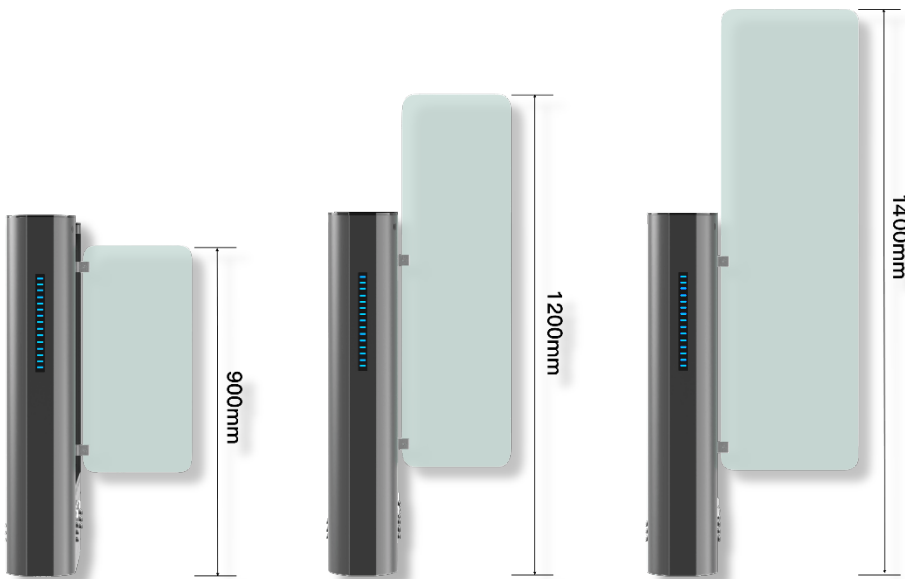

The height supports **900mm** or **1200mm** or **1400mm** to prevent unauthorized person from climbing over.

## Glass Width

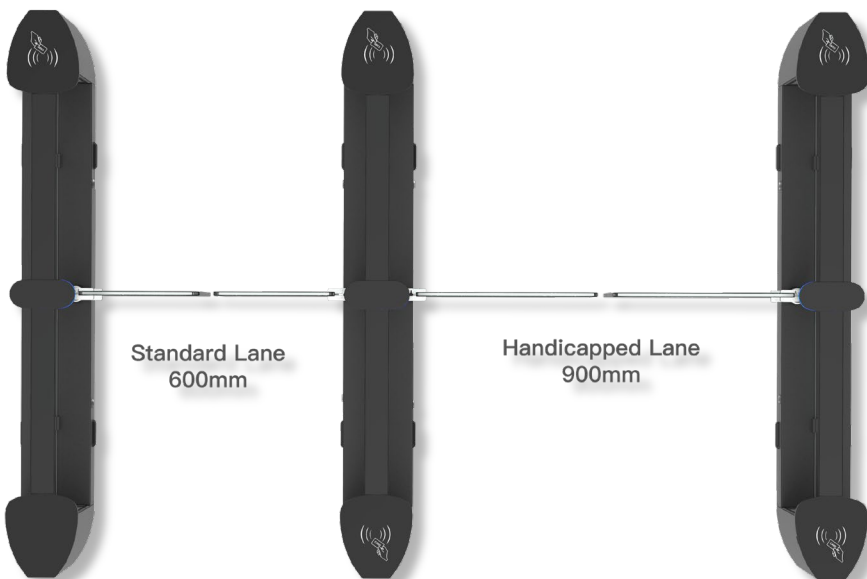

The passing width can reach to **600mm** for normal passage, and can support **900mm** arm for wide passageway, wheelchair, and pedestrian with large luggage can also pass.