



## Model DSN-50S

### Tripod Turnstile

Nebula DS-N50S is a tripod turnstile with twin rotate arm, one cabinet with two 550mm passageways to improve traffic efficiency, it is cost-effective, exquisite and beauty, only one person can pass at one time, highest security to prevent the illegal trailing.

At the top, it's covered by a high black tempered glass, show up an attractive and impressive character. The full stainless-steel body is surrounded with dazzling decorative LED light bar which bring out an aesthetic and distinctive sense.

## Features

- Two way or one way working.
- Support integrated with any type of access control systems.
- Three colors LED Indicator interface: blue for power on, green for valid card access, red for invalid card access.
- Counter output interface: both entrance and exit can count accurately. The counter support only counts when the person passes through the turnstile, and does not count when the card is swiped but not passed through.
- Temporary constant opening function: The security guard can press the button once, and multiple people can pass through the turnstile freely.
- Fire alarm interface: connect to the fire alarm, and the door will automatically open.
- RS485 communication interface.
- Easy to install and maintain.
- 3 years warranty support.

## Customized Service

- Appearance color can be customized based on installation environment.
- Dimensions can be customized to meet your request.
- Logo can be customized.
- It can support customized integration of various access control solutions.
- Picture: high resolution and scene picture can be customized.

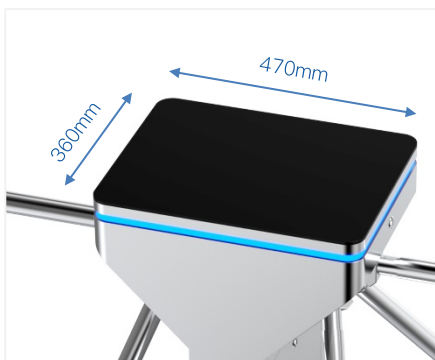

Small Size

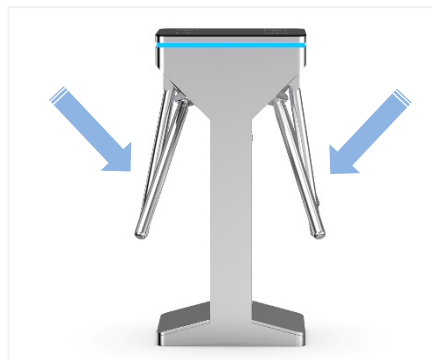

Arms Drop Down When Fire Alarm



Sturdy Bottom, No Shaking

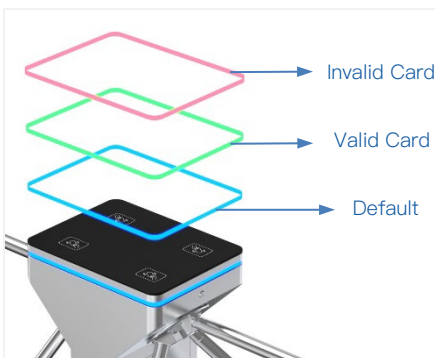

Three LED Indicators

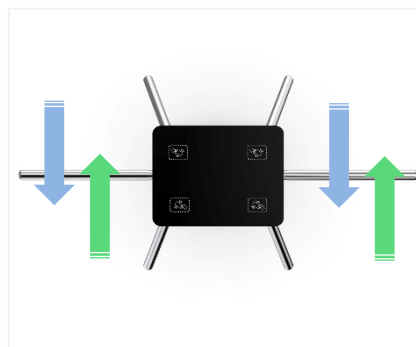

Single/Bi-directional Selectable



Anti-trailing Function:  
one person can pass at one time

# Access Control System

Daosafe turnstile gates can be well integrated with any 3<sup>rd</sup> party access control systems



Card Solution

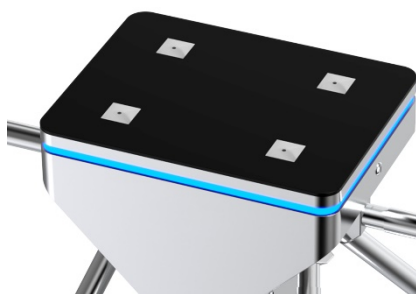

QR/Bar Code Solution



Biometric Solution



Remote Control



Touchless Button



Card



QR Code



Fingerprint



Face



Palm Vein

DSN-50S with card solution installed at office building



## Specifications

Model No.	DSN-50S
Type	Nebula Tripod Turnstile (double door type)
Brand	Daosafe
Certifications	Compliance CE, ROHS, FCC
Framework Material	304 brushed stainless steel High end black tempered film glass
Arm material	304 Stainless Steel (Black rubber protector is optional)
Dimension	470*360*980mm
Net Weight	60kg/pcs
Passage Width	550mm
Passing Direction	Single directional / Bi-directional
MCBF	10 million
Power Supply	AC220V/110V, 50/60Hz
Operation Voltage	24V DC
Power Consumption	40W
Operation Temperature	-20 °C - 75 °C
Operation Humidity	0 ~ 95% (No freeze)
Working Environment	Indoor / Outdoor
Flow Rate	35 people per minute
LED Indicator	Three LED indicators on top: blue→default, green → valid, red → invalid
Communication	Dry contact, Relay signal, RS485
Emergency	Arms will drop down automatically
Flexibility	Integrate with any access control



## Dimensions

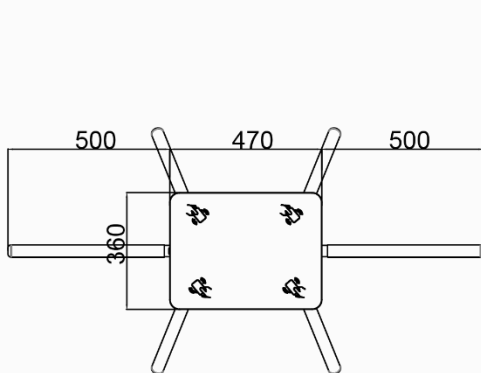

Top View

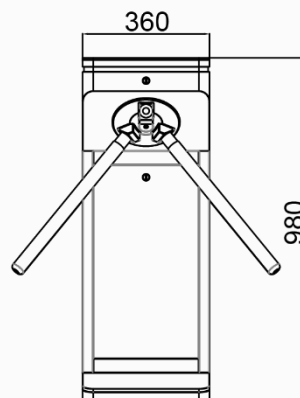

Side View

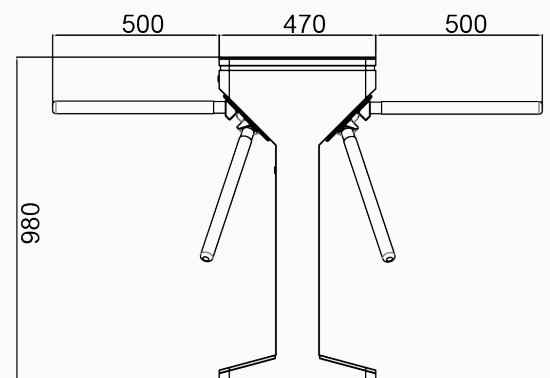

Front View