



Model DS-Q60H

Speed Gate

DS-Q60 short speed gate is tiny and compact designed for small spaces with higher security. With 55 persons passing per minute which is perfect for the sites with big visitor's flow rate. Supporting 600mm-900mm for wide passageway, wheelchair, and pedestrian with large luggage can also pass, and support extend height to 900-1800mm for enhancing security. The material is available in white/black steel powder coating and 304 stainless steel.

Features

- Two way or one way working.
- Tiny and compact design, ideal for small space.
- Support integrated with any type of access control systems.
- 0.1S fast open speed, 55 person/min high throughput.
- Passage width can be extended to 900mm and the height can be extended to 1800mm.
- Lower power consumption.
- Low noise, system runs smoothly.
- Green and red LED indicator display passing status.
- Indoor / Outdoor (shelter)
- Fire safety requirements, arms open automatically.
- Easy to install and maintain.

Customized Service

- Appearance color can be customized based on installation environment.
- Dimensions can be customized to meet your request.
- Logo can be customized.
- Arm glass width and height are optional.
- Infrared sensor number optional.
- Waterproof optional.
- Picture: high resolution and scene picture can be customized.

Functions

- **Infrared sensor alarm function:**
in case of illegal intrusion and reverse intrusion.
- **Anti-intrusion function:**
the gate is locked automatically until valid opening signal input.
- **Anti-reverse function:**
the turnstile alarms if someone wants to entry in the reverse direction.
- **Anti-trailing function:**
the speed gate alarms if someone wants to burst in without permission.
- **Anti-collision and anti-kick function:**
it designed with consolidated and more durable mechanism, will not break even someone collide it.
- **Mechanism self-protection:**
the arm will reset automatically if off position. The movement will not be broken or damaged even hit.



Logo Custom

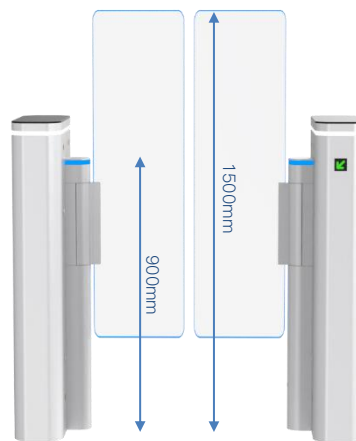

High Glass Optional

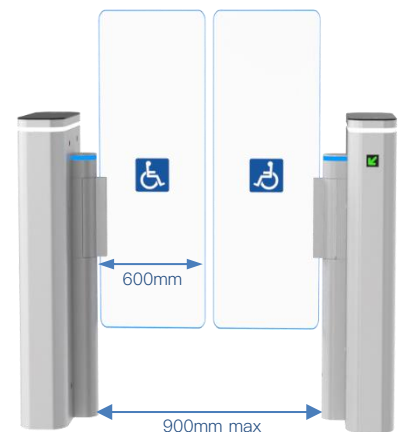

Wide Lane Optional



Anti-kick Function



55 Person/min Throughput

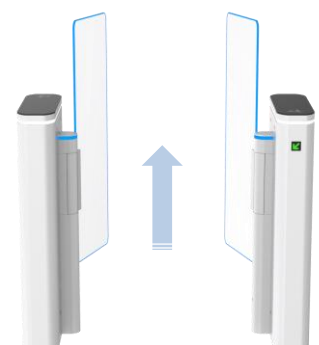

Fire Safety Requirements,
Arms Open Automatically

Access Control System

Daosafe turnstile gates can be well integrated with any 3rd party access control systems



Card Solution



QR/Bar Code Solution



Biometric Solution



Remote Control



Touchless Button



Card



QR Code



Fingerprint



Face



Palm Vein

Three lanes with handicapped lane for card solution installed at library



Specifications

Model No.	DS-Q60H
Type	Quantum Speed Gate
Brand Logo	Daosafe
Framework Material	Steel White and black stoving varnish Tempered glass
Arm material	Plexiglas-transparency
Dimension	450 * 160 * 978mm
Net Weight	50kg/pcs (single core) 70kg/pcs (double core)
Passage Width	600mm (standard), 900mm (handicap)
Arm Height	900mm (standard), 1800mm max. (optional)
Passing Direction	Single directional / Bi-directional
MCBF	15 million
Power Supply	AC220V/110V, 50/60Hz
Operation Voltage	24V DC
Power Consumption	40W
Operation Temperature	-20 °C – 75 °C
Operation Humidity	0 ~ 95% (No freeze)
Working Environment	Indoor / Outdoor (shelter)
Flow Rate	55 people per minute
LED Indicator	Two LED indicators on top: green → entry, red × no entry
Infrared Sensor	5 pairs (standard)
Emergency	Automatic arm open when power off
Communication	Dry contact, Relay signal, RS485
Flexibility	Integrate with any access control

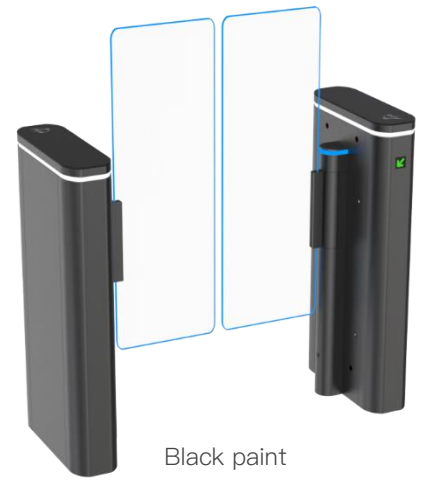

Black paint

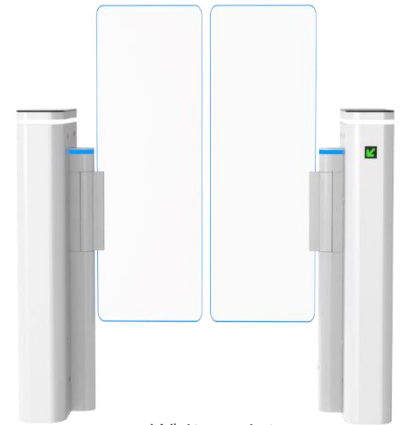

White paint



Stainless steel material

Dimensions

Top View

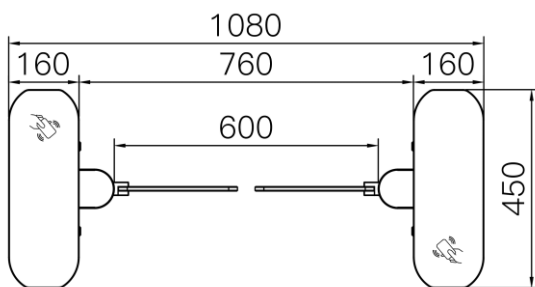

Front View

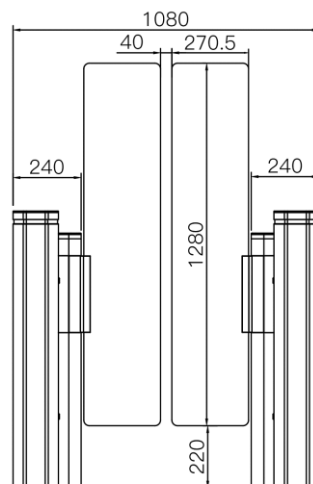

Side View

