



Model DS-Q30

Optical Flap Turnstile

DS-Q30 Quantum optical flap turnstile is the most sturdy and reliable model, with speeds up to 55 persons per minute. Which can be ideal installed at metro, station, office building and other places where vast visitors passing through.

Design with classic black, white color appearance, elegant and timeless pairing, perfect for using at high end applications.

Features

- Two way or one way working.
- Support integrated with any type of access control systems.
- 0.1S fast open speed, 55 person/min high throughput.
- Lower power consumption.
- Low noise, system runs smoothly.
- Green and red LED indicator display passing status.
- IP65 waterproof level, indoor/outdoor use.
- Fire safety requirements, arms retract automatically.
- Easy to install and maintain.
- 3 years warranty support.

Customized Service

- LED light strips(blue/green/red) display on the arm glass are optional.
- Appearance color can be customized based on installation environment.
- Dimensions can be customized to meet your request.
- Logo can be customized.
- Infrared sensor number optional.
- Picture: high resolution and scene picture can be customized.

Functions

- **Infrared sensor alarm function:**
in case of illegal intrusion and reverse intrusion.
- **Anti-intrusion function:**
the gate is locked automatically until valid opening signal input.
- **Anti-reverse function:**
the turnstile alarms if someone wants to entry in the reverse direction.
- **Anti-trailing function:**
the speed gate alarms if someone wants to burst in without permission.
- **Anti-collision and anti-kick function:**
it designed with consolidated and more durable mechanism, will not break even someone collide it.
- **Mechanism self-protection:**
the arm will reset automatically if off position. The movement will not be broken or damaged even hit.



3 Colors LED Light Strips on Glass



Logo Custom



Bi-directional Passage



Alarm Function



Anti-reverse Function

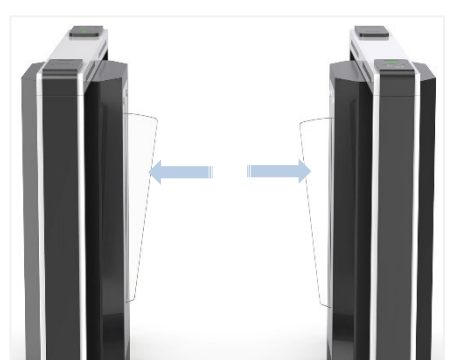

Fire Safety Requirements,
Arms Retract Automatically

Access Control System

Daosafe turnstile gates can be well integrated with any 3rd party access control systems



Card Solution

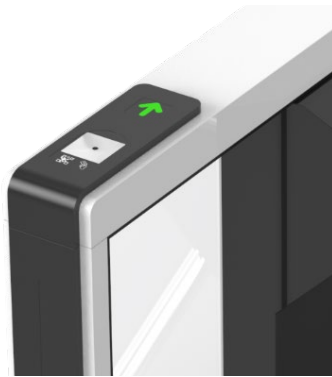

QR/Bar Code Solution



Biometric Solution



Remote Control



Touchless Button



Card



QR Code



Fingerprint



Face



Palm Vein

Two lanes for card solution installed at office



Specifications

Model No.	DS-Q30
Type	Quantum Optical Flap Turnstile
Brand	Daosafe
Framework Material	Steel White and black stoving varnish Tempered glass
Arm material	Plexiglas–transparency
Dimension	1400 * 280 * 978mm
Net Weight	65kg/pcs (single core), 75kg/pcs (double core)
Passage Width	550mm
Passing Direction	Single directional / Bi-directional
MCBF	12 million
Power Supply	AC220V/110V, 50/60Hz
Operation Voltage	24V DC
Power Consumption	40W
Operation Temperature	-20 °C – 75 °C
Operation Humidity	0 ~ 95% (No freeze)
Working Environment	Indoor / Outdoor (shelter)
Flow Rate	55 people per minute
LED Indicator	Two LED indicators on top: green → entry, red × no entry
Infrared Sensor	5 pairs (standard)
Emergency	Automatic arm open when power off
Communication	Dry contact, Relay signal, RS485
Flexibility	Integrate with any access control



Dimensions

Top View

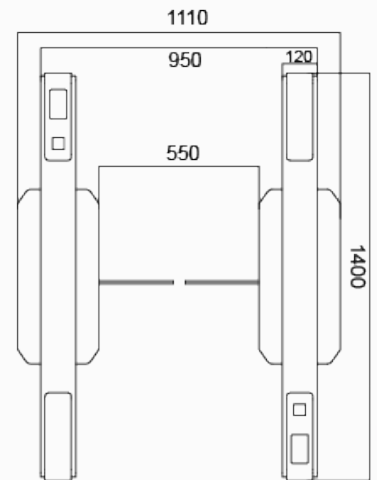

Front View

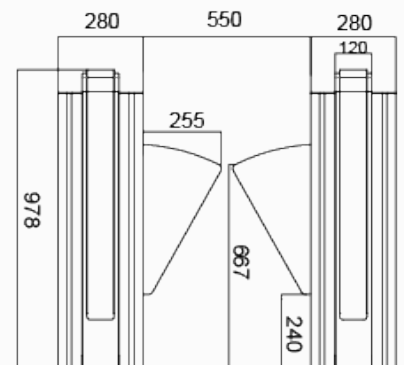

Side View

