

- Keypad operation
- All metal housing
- Simple installation
- Non-handed (standard & vertical body styles)
- Meets IP55 rating
- Standard, vertical, or horizontal body style
- Brushed nickel finish
- Cam locking mechanism
- Visual & audible indicators
- Manage with code or electronic keys
- Dual functionality (shared or assigned)
- 3-5 year battery life
- Powered by 2 premium AAA batteries
- Up to 5 year warranty

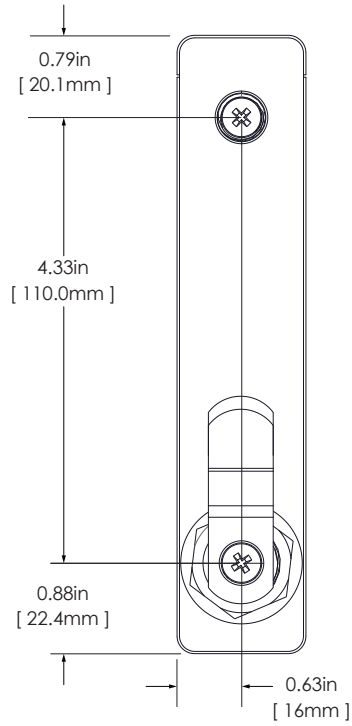

- Offset or straight cam
- Strike plate

## Back View



## Side View

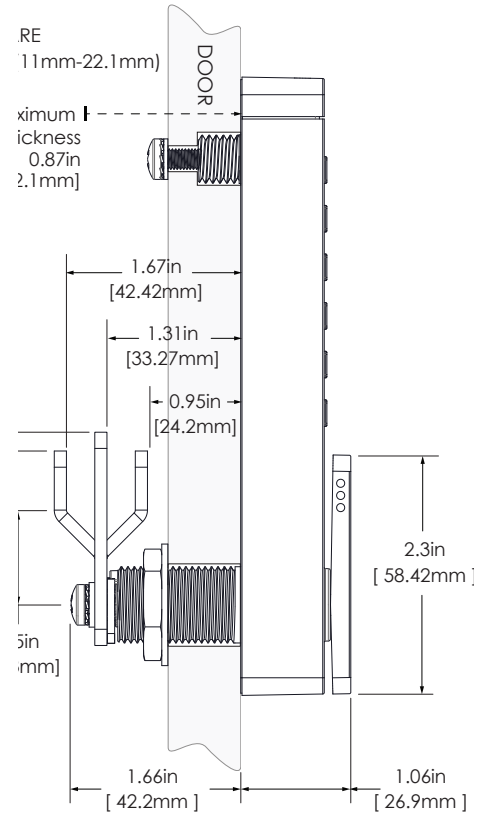

## Front View

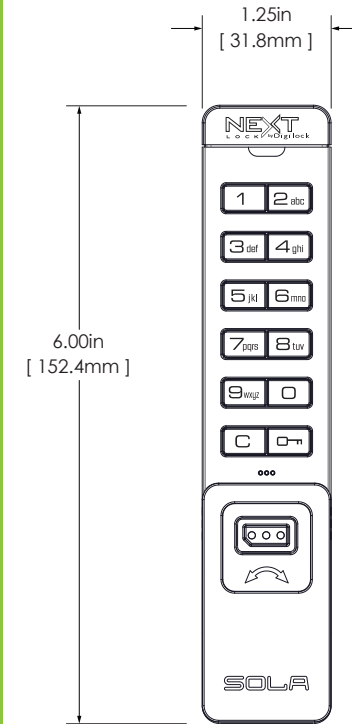

Standard Keypad locks with a pull handle and operated with a User Key are fully compliant with the Americans with Disabilities Act (ADA) guidelines set by the U.S. Access Board.

