

**Electromechanical
Tripod Turnstile
with Automatic
Anti-Panic Arms**

TTR-07.1

ASSEMBLY AND OPERATION MANUAL





**Electromechanical
Tripod Turnstile
with Automatic Anti-Panic Arms**

TTR-07.1

Assembly and Operation Manual

CONTENT

1	APPLICATION.....	3
2	OPERATION CONDITIONS.....	3
3	TECHNICAL SPECIFICATIONS	4
4	DELIVERY SET.....	5
4.1	Standard delivery set	5
4.2	Optional equipment supplied on request:.....	5
5	BRIEF DESCRIPTION	7
5.1	Main features	7
5.2	Design.....	7
5.3	Control over the turnstile	9
5.4	Input and output signals and their parameters when operating the turnstile	10
5.5	Control modes of the turnstile	11
5.6	Operation with the RC panel.....	12
5.7	Operation with the WRC	13
5.8	Operation with an ACS controller.....	13
5.9	Additional devices connectable to the turnstile	13
5.10	Emergency unblocking of the turnstile	15
5.11	Operation contingencies and response.....	15
6	MARKING AND PACKAGING.....	16
7	SAFETY REQUIREMENTS.....	16
7.1	Installation safety requirements	16
7.2	Operation safety requirements.....	16
8	INSTALLATION INSTRUCTIONS	17
8.1	Installation details	17
8.2	Installation tools	18
8.3	Length of cables.....	18
8.4	Installation procedure.....	18
9	OPERATION INSTRUCTIONS	22
9.1	Power- up	22
9.2	Operating modes of the turnstile in pulse control mode	22
9.3	Operating modes of the turnstile in potential control mode	24
9.4	Actions in emergency.....	24
9.5	Troubleshooting	25
10	MAINTENANCE	26
11	TRANSPORTATION AND STORAGE	27
	APPENDIX A Control signal algorithm in pulse control mode.....	28
	APPENDIX B Control signal algorithm in potential control mode.....	30

Dear Customer!

Thank you for purchasing the PERCo turnstile. Please follow the instructions given in the Manual carefully, and this quality product will provide many years of trouble-free use.

Assembly and Operation Manual (hereinafter - the Manual) for the **TTR-07.1 electromechanical tripod turnstile with automatic anti-panic folding arms** (hereinafter - the turnstile) contains data that is necessary for the most full use of operating advantages of the turnstile as well as chapters on packaging, installation and maintenance.

Only qualified personnel, following the instructions of this Manual, must carry out installation and maintenance.

Abbreviations:

- ACS — access control system;
- RC panel – remote control panel;
- WRC – wireless remote control;
- CLB – control logic board.

1 APPLICATION

The **TTR-07.1** electromechanical tripod turnstile with automatic anti-panic folding arms (hereinafter - the turnstile) is designed for managing pedestrian flows at entrance points of industrial facilities, banks, administrative buildings, retail outlets, railway terminals, airports providing free passageway in emergency situations.

To ensure fast and convenient passage it is recommended to install one turnstile per 500 people working the same shift, and on the basis of maximum working load 30 persons/min. See Chapter 3 for information on the throughput capacity of the turnstile.

2 OPERATION CONDITIONS

The turnstile with regard to resistance to environmental exposure complies with GOST15150-69, category NF4 (operation in premises with climate control).

Operation of the turnstile is allowed at ambient air temperature from +1°C to +40°C and at relative air humidity of up to 60% at + 20°C.

3 TECHNICAL SPECIFICATIONS

Operating voltage	12±1.2 V DC
Power consumption	max. 72 W
Consumption current	max. 6.0 A
Throughput rate in the single passage mode	30 persons/min
Throughput rate in the free passage mode	60 persons/min
Passage width	530 mm
Arm rotation force	max. 3 kgf
RC panel cable length ¹	min. 6.6 m
Ingress Protection Rating	IP41 under EN 60529
Electric shock protection class	III as per GOST R IEC 335-1-94
Mean time to failure	min. 1,500,000 passages
Mean lifetime	8 years
Turnstile overall dimensions (L×W×H)	798×752×1054 mm
Turnstile net weight	max. 38 kg

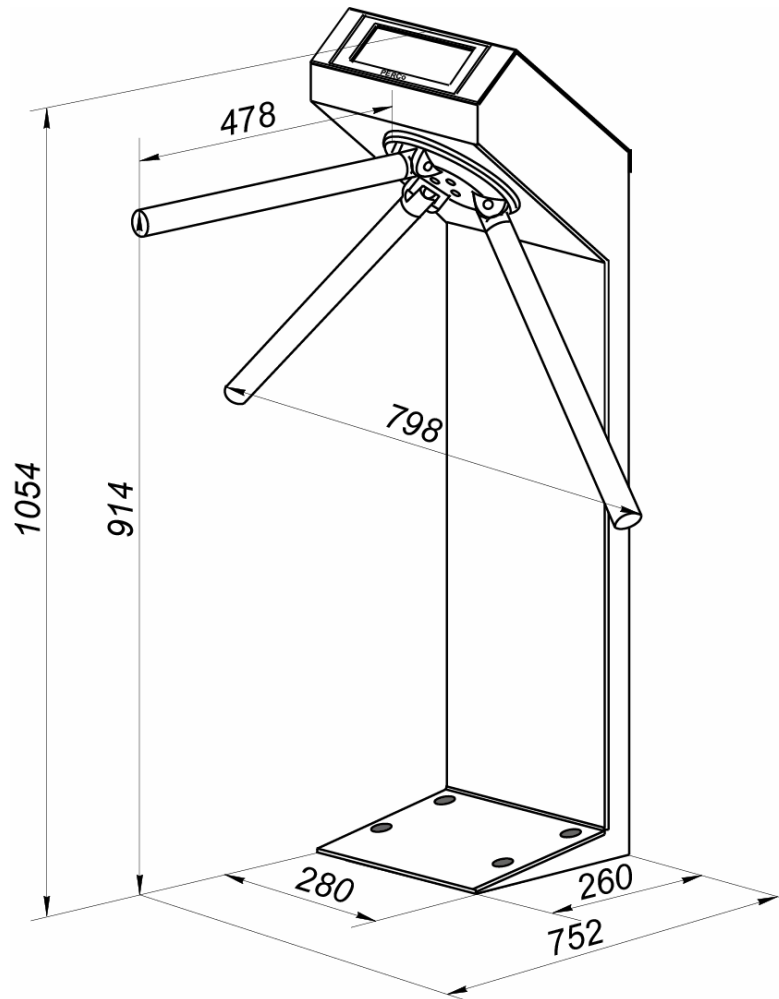

Figure 1. TTR-07.1 tripod turnstile. Overall dimensions

¹ MPS 8×0.12 mm. MAX allowed cable length – 40m. Using of cables more than 40 m long may result in interferences in a control line.

4 DELIVERY SET

4.1 Standard delivery set

Basic equipment:

Turnstile housing	1
Hub with barrier arms and fastening	1
RC panel with cable min. 6.6 m long	1

Installation tools:

Ø30 mm plug	5
Ø16 mm plug	1
Nylon cable tie 100 mm	5
Self-adhesive cable tie mount	3

Technical documentation:

Certificate	1
Assembly and operation manual	1

Package:

Box	1
-----------	---

4.2 Optional equipment supplied on request:

WRC kit (includes a receiver and transmitter (tag) with operation range up to 40 m)	1
Siren (for alerts on unauthorized entry attempts)	1
Intrusion detector	1
Anchor PFG IH 10	4
Power supply unit	1



Note:

Power supply for turnstile housing is not included in the standard deliver set and is customer supply. MPS: 12V DC @ 6A.

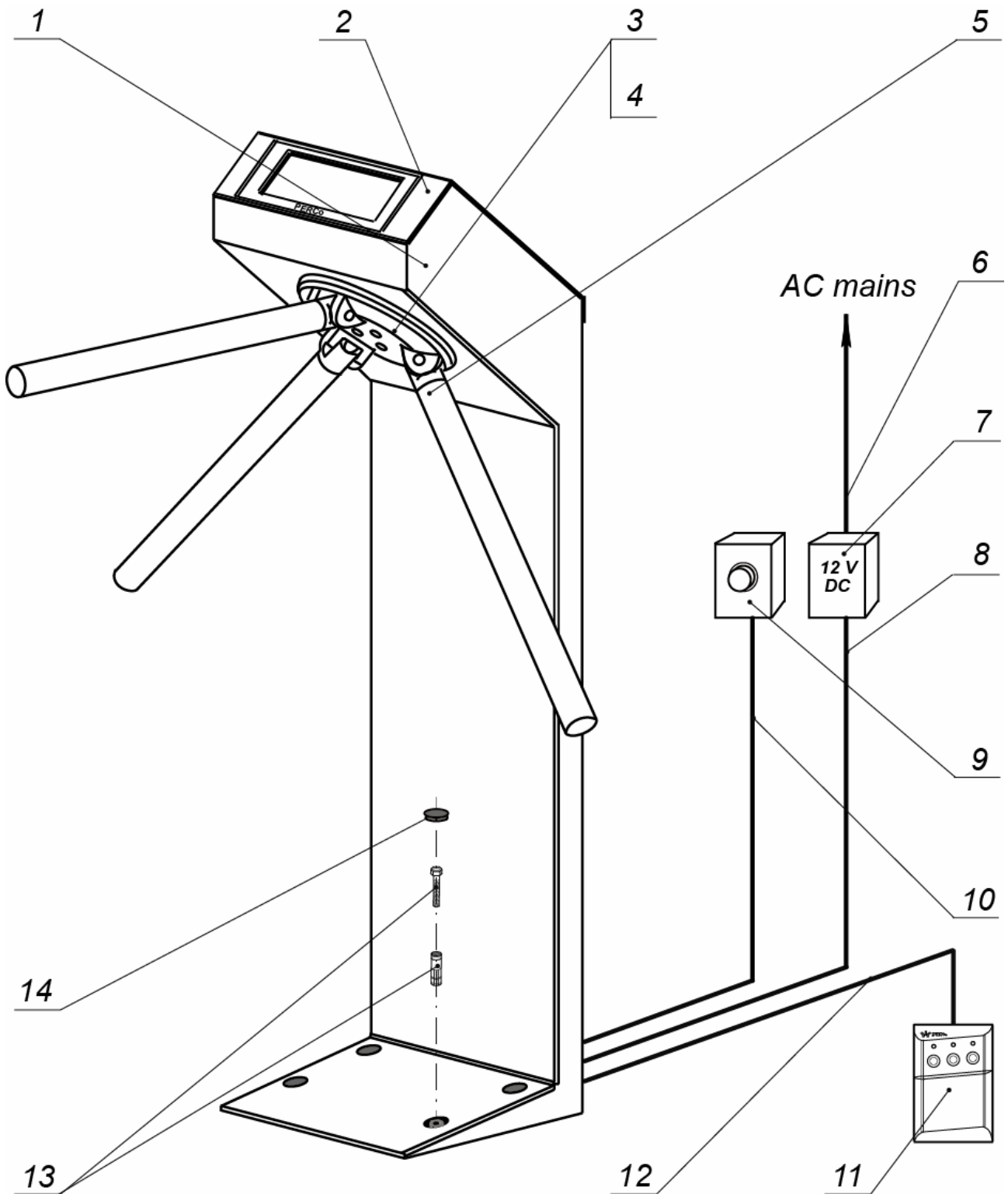

Figure 2. Turnstile overall view

- 1 – turnstile housing; 2 – cover with LED indication display; 3 – hub;
- 4 – hub fastening bolts; 5 – barrier arm; 6 – AC power cable; 7 – turnstile power supply;
- 8 – turnstile power cable; 9 – emergency unblocking device (“Fire Alarm”);
- 10 – emergency unblocking device cable;
- 11 – RC panel / WRC kit / ACS controller;
- 12 – cable of RC / WRC / ACS controller;
- 13 – PFG IR 10-15 anchor bolt; 14 – plug Ø30

5 BRIEF DESCRIPTION

5.1 Main features

- The turnstile can be operated from the RC panel or WRC as well as from an ACS.
- The turnstile is supplied with safe voltage — maximum 14V.
- The turnstile has power consumption — maximum 72W (in start-up mode).
- Automatic unblocking of passageway is performed by bringing the barrier arm into vertical position at a power loss or by alarm signal.
- After each passage the turnstile provides automatic complete rotation of the barrier arms to home position, i.e. automatic reset.
- After the turn of barrier arm for more than 60° angle its reverse rotation is blocked.
- Smoothness of reset and quiet operation are ensured by a damper.
- The optical arm rotation sensors are built into the turnstile housing to ensure accurate count of inputs to an ACS.
- The turnstile has relay outputs for connection of an intrusion detector and a siren.
- There are two modes for the turnstile control — a pulse control mode and a potential control mode.
- Galvanic decoupling of the outputs ensures noise-immunity of the turnstile electronics.
- The turnstile has outputs for connection of remote indicators.
- A purpose-designed «Fire alarm» control input is intended for unlocking the turnstile at the fire alarm command or from emergency unblocking button.
- The turnstile requires a power supply source with a load current minimum 6 A in 5 sec.

5.2 Design

The design of the turnstile is shown in Fig. 2. Numbers in brackets correspond to Fig. 2 of this Manual.

5.2.1 The turnstile comprises a turnstile housing (1) with set of barrier arms (5) and RC panel (11). The turnstile housing (1) is a formed and welded metal structure with a cover (2). On the front panel of the cover there is a LED indication display. Inside the turnstile housing there are CLB and a self-centering mechanism consisting of a resetting device (a pusher, springs and a roller), a control mechanism with optical arm rotation sensors and a locking device, and electromechanical barrier arm unblocking device. The self-centering mechanism also contains a damper, an arm rotation sensor disc and a hub (3) with three barrier arms (5).

5.2.2 The large LED indication display with bright pictograms (located on the cover (2)) is intended for status and direction indication: a Green Arrow indicates the direction of authorised passage (the turnstile is open in the set direction); a Red Cross indicates ban on passage (the turnstile is locked).

5.2.3 The RC panel / WRC / ACS controller (11), emergency unblocking device, LED indication display, control mechanism and the turnstile power supply unit (7) are connected to the CLB with the cables in accordance with the connection layout (see Fig.11).

5.2.4 The RC panel is designed as a small desktop device with a shockproof ABS plastic case and is intended for setting and indicating operating modes when the turnstile is operated manually. The RC panel overall view is shown in Fig. 3.

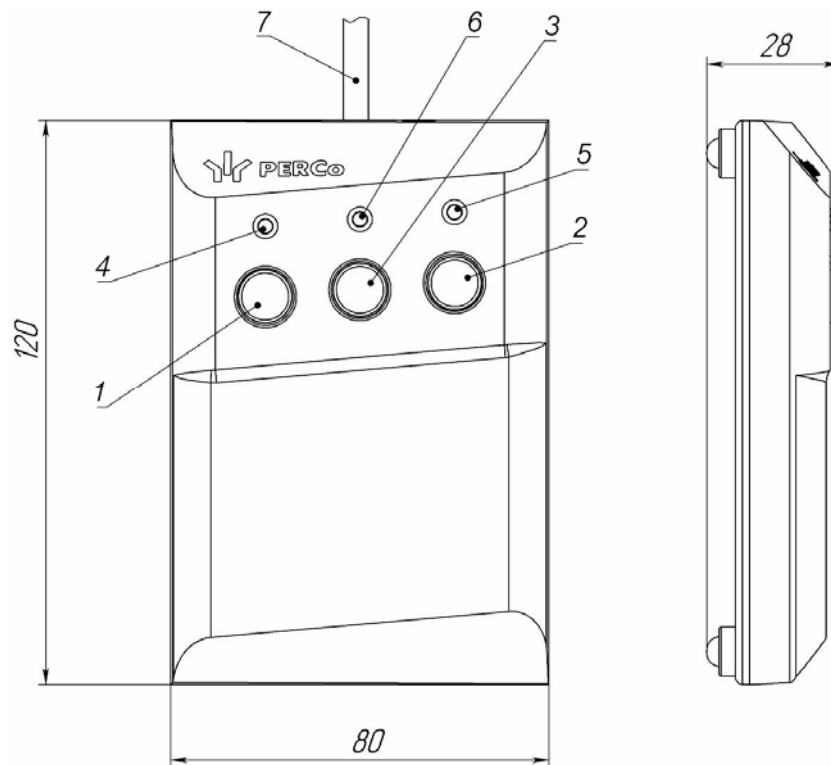

Figure 3. RC panel overall view

- 1, 2, 3 – buttons **LEFT**, **RIGHT**, **STOP** for setting the passage mode;
 4, 5 – green indicators «*Left*», «*Right*»;
 6 – red indicator «*Stop*», 7 – RC cable.

There are three control buttons on the RC front panel intended for setting the turnstile operating modes. The LED indicators are located above the buttons. The middle button on the RC panel (hereinafter — the **STOP** button) is intended to set the turnstile to the “Always locked” mode. The left (**LEFT**) and the right (**RIGHT**) buttons are intended to unlock the turnstile for passage in the chosen direction.

The RC panel is connected to the CLB with a multicore cable (12) via the “XT1.L” connector block (See Fig. 4 and Fig. 11).

If the turnstile orientation relatively to the operator’s terminal is not standard (e.g. the terminal is placed at the backside of the turnstile housing), the RC panel orientation towards the turnstile can be changed by exchanging places of the RC wires to the contacts “Unlock A” and “Unlock B” as well as contacts “Led A” and “Led B” accordingly (see Fig. 4 and Fig. 11).

5.2.5 The CLB (Fig. 4) includes:

- **X1 (LED)**, **X2 (SENS)**, **X3 (MOTOR)** connectors to connect the indication module, optical arm rotation sensors and control mechanism with a locking device (from the X1, X2, X3 connectors with the turnstile cable);
- **XT1.L (In)** connector block to connect the RC panel / the WRC / ACS controller (11) inputs as well as an emergency unblocking device (*Fire Alarm*) (9) and intrusion detector;
- **XT1.H (Out)** connector block to connect a siren and ACS outputs, providing the turnstile status data to the ACS controller;
- **XT3 (+12VDC)** connector block to connect the turnstile power supply;
- **XT4 (Light A)** and **XT5 (Light B)** connector blocks to connect “open/closed” remote indicators, one indicator per each direction;

- **XT6 (AntiPanic)** connector block to connect the electromagnet of automatic anti-panic unblocking device;
- **J1** connector to select the turnstile control mode, the jumper is fixed — the pulse control mode, the jumper is not fixed — the potential control mode. The jumper is fixed at the factory before the delivery
- **J2** connector for programming.
- **Power** – power LED indicator on the control board.

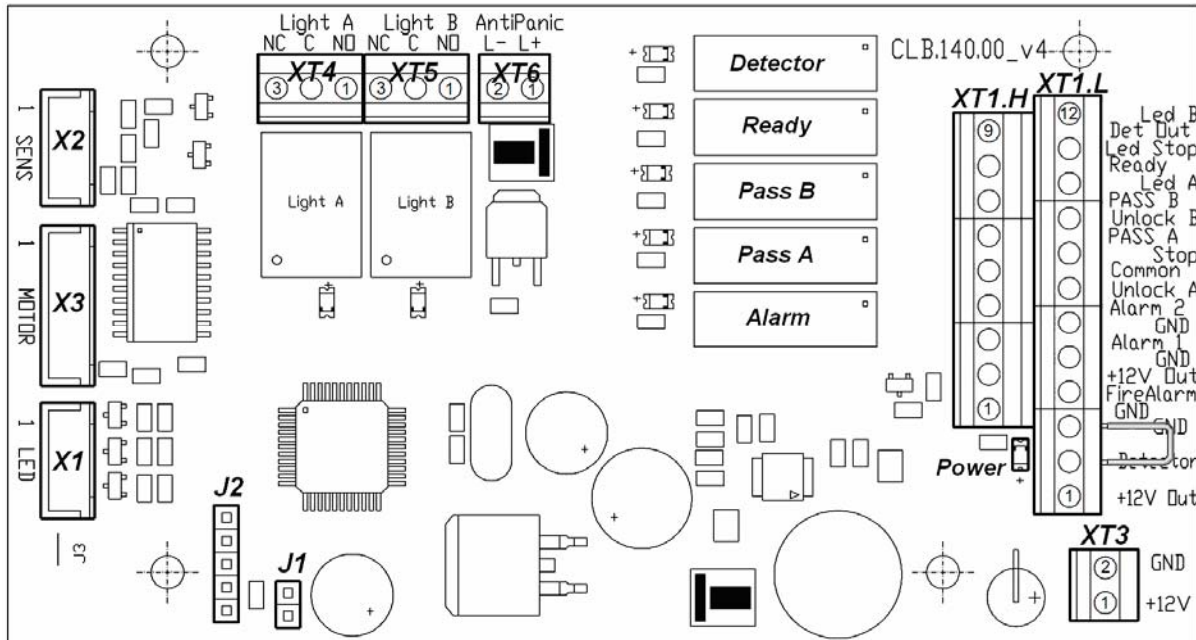

Figure 4. Control Logic Board (CLB)

5.3 Control over the turnstile

5.3.1 The turnstile can be operated from the following control devices:

- the RC panel;
- WRC;
- the ACS controller.

The above devices can be connected to the turnstile as follows:

- any device separately;
- in any combination with each other;
- all devices simultaneously (in parallel).



Note:

At the parallel connection of the above devices to the turnstile the superposition of the control signals from them may occur. In that case the turnstile response will conform to response to the obtained combination of input signals. (App. A and B).

5.3.2 Connection of the devices stated in Clause 5.3.1 is made with the cable (5) to the corresponding connector blocks XT1.L and XT1.H of the CLB in accordance with the connection layout (Fig. 4 and Fig. 11).

5.3.3 The RC is connected to the contacts *GND*, *Unlock A*, *Stop*, *Unlock B*, *Led A*, *Led Stop* and *Led B* of the XT1.L. connector block.

5.3.4 WRC is connected to the contacts *GND*, *Unlock A*, *Stop* and *Unlock B* of the XT1.L. connector block.

5.3.5 The ACS controller outputs are connected to the contacts *GND*, *Unlock A*, *Stop* and *Unlock B* of the *XT1.L* connector block.

5.3.6 The ACS controller inputs are connected to the contacts *Common*, *PASS A*, *PASS B*, *Ready* and *Det Out* of the *XT1.H* connector block.

5.3.7 Pin assignments of the CLB connector blocks are given in Fig. 4.

5.4 Input and output signals and their parameters when operating the turnstile

5.4.1 The CLB microcontroller processes the incoming commands (i.e. traces the status of the contacts “*Unlock A*”, “*Stop*”, “*Unlock B*” and “*Fire Alarm*”), keeps track of the signals from the optical arm rotation sensors and from the intrusion detector (contact “*Detector*”), and basing on those signals, generates commands to the control mechanism and to the external devices – indication on the RC panel (“*Led A*”, “*Led Stop*” and “*Led B*”), the signal of hub turning in the corresponding direction (“*PASS A*” and “*PASS B*”), the signal of the turnstile ready for a current command (“*Ready*”), the alarm output signal (“*Alarm*”) — and relays the signal of the current status of the intrusion detector (“*Det Out*”).

5.4.2 The turnstile is operated by input of a low-level signal to the “*XT1.L*” connector block contacts “*Unlock A*”, “*Unlock B*” and “*Stop*” relatively to the “*GND*” contact. As the control element there can be used a normally open relay contact or a circuit with open collector output at that. At the emergency the turnstile control is carried out by removing of a low-level signal from the “*Fire Alarm*” contact relatively to the “*GND*” contact. As the control element there can be used a normally closed relay contact or a circuit with open collector output at that (Fig. 5 and Fig. 6).

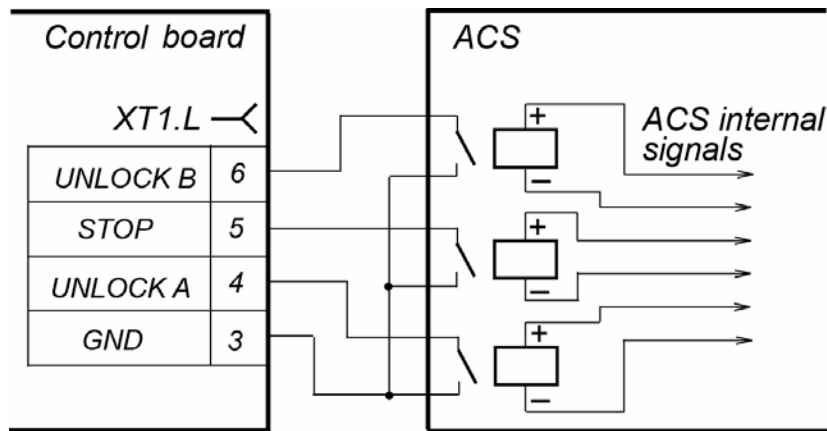

Figure 5. ACS control element — normally open relay contact

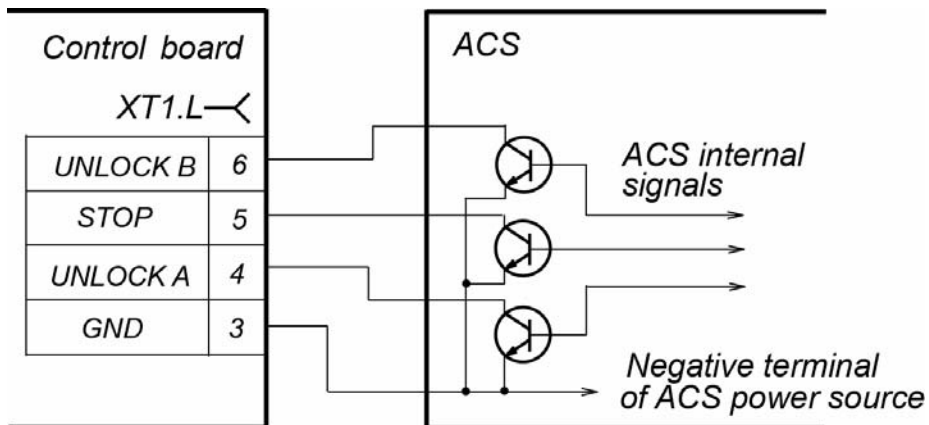

Figure 6. ACS control element — circuit with open-collector output

**Note:**

For generating of a high-level signal at all the input contacts (*Unlock A*, *Stop*, *Unlock B*, *Fire Alarm* and *Detector*) 2kOhm resistors connected to the power supply bus “+ 5V” are used.

The control element* must provide the following signal characteristics:

* the relay contact as the control element:

minimum switched currentmax. 2 mA
 closed contact resistance
 (with the resistance of the connected cable) max. 300 Ohm

*the circuit with open-collector output as the control element:

voltage at the closed contact
 (low - level signal at the CLB input)max. 0.8 V

5.4.3 The relays *PASS A* (contacts *PASS A* and *Common*), *PASS B* (contacts *PASS B* and *Common*), *Ready* (contacts *Ready* and *Common*), *Detector* (contacts *Det Out* and *Common*) and *Alarm* (contacts *Alarm 1* and *Alarm 2*) have normally open contacts. The “*Common*” contact, at that, is not connected to the CLB power supply negative terminal. In the initial (inactive) state, when the power is on, the relay contacts “*PASS A*”, “*PASS B*”, “*Ready*” and “*Detector*” are closed (voltage is supplied to the relay coil) and the “*Alarm*” relay contacts are broken (voltage is not supplied to the relay coil). The CLB relay operation/release is indicated by lighting up/going down of the red test indicators located near the corresponding relays (Fig. 4). The output cascades for *PASS A*, *PASS B*, *Ready*, *Det Out* and *Alarm* are the contacts with the following signal characteristics (Fig 7):

maximum commutation voltage 42 VDC
 maximum switched current 0.25 A
 closed contact resistance..... max. 0.15 Ohm

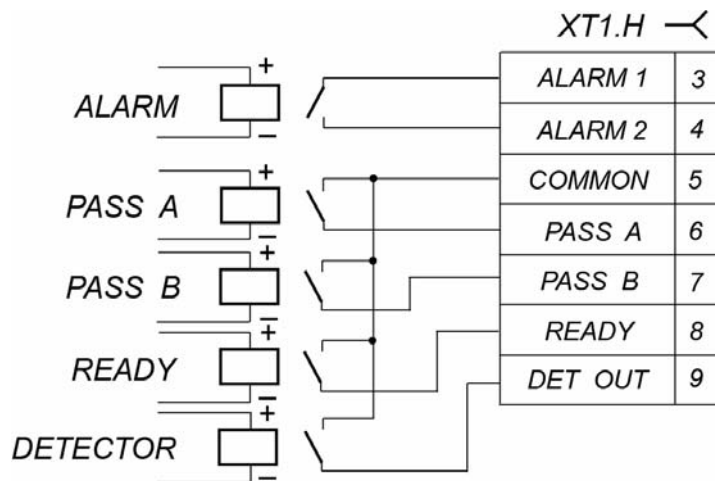

Figure 7. Output cascades for PASS A, PASS B, Ready, Det Out and Alarm

5.5 Control modes of the turnstile

5.5.1 There are two modes of the turnstile control - a pulse control mode and a potential control mode. They determine available operating modes of the turnstile (Table 2 and Table 3).

5.5.2 The control mode is set by the jumper on the J1 connector (the J1 connector location is shown on Fig. 4 and on a label located on the inner surface of turnstile cover (2)): the jumper is fixed — the pulse control mode, the jumper is not fixed — the potential control mode. The jumper is fixed at the factory before the delivery.

5.5.3 Control over the turnstile is effected by input of the control signal to the turnstile at both control modes. The passage waiting time in the pulse control mode is 5 seconds regardless of the control signal length. In the potential control mode the passage waiting time equals the length of the control signal.

5.5.4 The pulse control mode is intended for the turnstile operation from the RC panel, WRC or the ACS controller, outputs of which support the pulse control mode.

Standard control inputs: *Unlock A*, *Stop* and *Unlock B*.

Special control input: *Fire Alarm*.

See Table 2 for the turnstile operating modes at this control mode.

The algorithm of control signals at this mode is stipulated in Appendix A.

The minimum input signal duration, when the operating mode can be changed, should be 100 ms. The passage waiting time is 5 sec. and it does not depend on the input signal duration.

See Clause 5.10. for the turnstile operation at special “Fire Alarm” control input.

5.5.5 The potential control mode is intended for the turnstile operation from the ACS controller, outputs of which support the potential control mode (for example, a lock controller).

Standard control inputs: *Unlock A* and *Unlock B*.

Special control inputs: *Stop* and *Fire Alarm*.

See Table 2 for the turnstile operating modes at this control mode.

The algorithm of control signals at this mode is stipulated in Appendix B.

The minimum input signal duration, when the operating mode can be changed, should be 100msec. The passage waiting time is equal to the low-level signal duration (the turnstile remains open in the set direction if a low-level signal exists at the set direction input by the moment of passage).

At the low-level signal inputting to the “*Stop*” input, both directions are locked for the time of the signal duration regardless the signal strength at the inputs “*Unlock A*” and “*Unlock B*”. At the low-level signal removing from the “*Stop*” input, the directions are set to the control mode according to the signal strength at the inputs “*Unlock A*” and “*Unlock B*”.

See Clause 5.10 for the turnstile operation at the special “Fire Alarm” control input.

5.6 Operation with the RC panel

5.6.1 When the buttons on the RC panel are pressed (the **STOP** button and the two other buttons corresponding to the passage direction), the closing of the relevant contact “*Stop*”, “*Unlock A*” or “*Unlock B*” to the contact “*GND*” occurs (i.e. forming of the low-level signal relatively to the contact “*GND*”).

5.6.2 Operation logic of the turnstile at the single passage in the A(B) direction at the pulse control mode:

5.6.2.1 When the button, corresponding to the A (B) passage direction, is pressed on the RC panel, the closing of the contact “*Unlock A(B)*” to the contact “*GND*” occurs (i.e. forming of the low-level signal on the contact “*Unlock A(B)*” relatively to the contact “*GND*”).

5.6.2.2 The CLB microcontroller processes the incoming command and generates the command to the control mechanism, which opens the A (B) passage direction (lifts the upper (lower) edge of the key holt).

5.6.2.3 The microcontroller traces the status of the optical arm rotation sensors, which become active/passive in a certain consequence at the barrier arm rotation, and counts the time passed since the moment of pushing the RC button corresponding to the permitted passage direction A (B).

5.6.2.4 At the barrier arms turning at 67° the microcontroller forms signal “PASS A (B)” (breaking the contacts “PASS A (B)” and “Common” takes place).

5.6.2.5 After the barrier arms turning at 67° or after 5 seconds since the moment of pushing the RC button corresponding to the permitted passage direction A (B), the microcontroller generates a command to the control mechanism, which closes the passage direction A (B) (drops down the upper (lower) edge of the key holt).

5.6.2.6 When the barrier arms reset to home position (barrier arms turning at 112°), the microcontroller removes the signal “PASS A (B)” (contacting the “PASS A (B)” and “Common” takes place). (PASS A(B) signal duration is min. 250 ms).

5.6.3 The “Always free” operating mode particularity: in this mode the command described in Clause 5.6.2.5 is not generated and the set passage direction remains open.

5.7 Operation with the WRC

5.7.1 Control over the turnstile with the WRC is similar to that with the RC panel.

5.7.2 The buttons on the WRC tag act the same way as those on the RC panel.

5.7.3 The WRC operation manual is supplied with that device.

5.8 Operation with an ACS controller

5.8.1 In the pulse control mode control over the turnstile with an ACS controller is similar to that with the RC panel.

5.8.2 In the potential control mode control over the turnstile with an ACS controller is similar to that with the RC panel and lies in forming of low-level signal on the contacts “Unlock A”, “Stop” and “Unlock B” relatively to the contact “GND”.

5.8.3 The difference of the operation logic in the potential control mode and in the pulse control mode (as per Clause 6.6.2): the command described in Clause 6.6.2.5 is generated only at the moment of releasing the RC button, corresponding to the passage direction A(B).

Therefore for arranging single passages in the potential control mode it is recommended to remove the control low-level signal at the beginning of the “PASS” signal for the corresponding direction.

5.8.4 The passage through the turnstile in the A (B) direction is fixed in accordance with the status of the output contacts “PASS A(B)” and “Common”.

5.9 Additional devices connectable to the turnstile

5.9.1 The following external devices can be connected to the turnstile:

- intrusion detector;
- siren;
- emergency unblocking device (9);
- remote indicators.

5.9.2 The intrusion detector is connected to the “XT1.L” connector block, and the siren is connected to the “XT1.H” connector block of the CLB according to the connection layout (Fig. 4 and Fig. 11). There should be normally closed contacts on the intrusion detector.

If intrusion detector is not connected, you must install the jumper between pins *DETECTOR* and *GND* to the “*XT1.L*” connector block. On delivery, this jumper is installed.

5.9.3 If the turnstile is locked (the “*Always locked*” mode / “*Both directions closed*” mode when both directions are locked, Tables 2 and 3) and a signal comes from the intrusion detector, the “*Alarm*” signal is generated. The “*Alarm*” signal is disabled after 5 sec. or by executing of any received command. The signal from the intrusion detector is ignored for the period of authorized unlocking of the turnstile in either or both directions.

If within 3 sec. after the “*Always locked*”/“*Both directions closed*” mode is set, the signal from the intrusion detector comes, it is also ignored.

The intrusion detector status signal is constantly transmitted to the “*Det Out*” and “*Common*” contacts of the CLB “*XT1.H*” connector block (Fig. 4).

5.9.4 The emergency unblocking device is connected to the “*XT1.L*” connector block of the CLB in accordance with the connection layout (Fig. 4 and Fig. 11). If the “*Fire Alarm*” input is not used, it is necessary to set a jumper between the contacts “*Fire Alarm*” and “*GND*”. This jumper is preset at the factory.

Operation of the turnstile under commands of the emergency unblocking device is stipulated in clause 5.10.

5.9.5 The remote indicators^{**}) are connected to the connector blocks “*XT4*” (“*Light A*”) and “*XT5*” (“*Light B*”). At that the “*Light A*” (“*Light B*”) relay is active (the voltage is supplied to the relay coil), when the “*Green arrow*” pictogram on the LED indication display, corresponding to the set passage direction, lights, and it is passive, when the “*Green arrow*” pictogram on the Led display does not light. The response/release of the relays “*Light A*” and “*Light B*” can be defined according to lighting up/going down of the red indicators, which are installed near the above mentioned relays (Fig. 4). Output cascades for the “*Light A*” and the “*Light B*” relays are non bridging relay contacts (Fig. 8) with the following signal characteristics:

maximum switched voltage	30 VDC
maximum switched voltage	42 VAC
maximum switched AC/DC.....	3 A
closed contact resistance	max. 0.15 Ohm

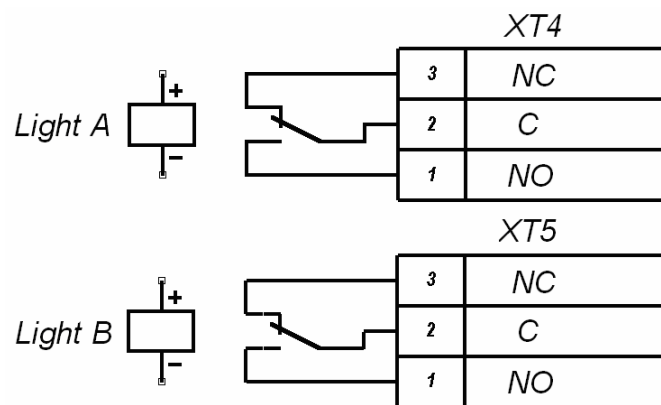

Figure 8. Output cascades for Light A and Light B

5.10 Emergency unblocking of the turnstile

Emergency unblocking of the turnstile is automatically performed at a power supply loss, e.g. breakdown of connected power supply unit. At that the barrier arm automatically falls down ensuring free passage. The turnstile will remain in such condition until the power is restored. The setting of the turnstile into the active mode is similar to the standard switching on procedure.

Automatic anti-panic function is also activated by Fire Alarm signal along with both green arrows at the indication module. The central barrier arm will be automatically dropped down allowing the free passage. Green arrows on the indication module will be activated in the simultaneous flashing mode, until the Fire Alarm signal is off. When it is off, the red cross will be activated on the indication module and the turnstile will be set into the stand-by mode with a dropped down arm.

If the Fire Alarm signal is received while the hub with folding arms is rotating, the flashing of green arrows will be activated, but the emergency unblocking function will be activated only after the rotation is finished.

After restore of power supply or *Fire Alarm signal* removal the arm shall be manually set into operating position, after that the turnstile is ready for further standard operation.

5.11 Operation contingencies and response

5.11.1 The turnstile is capable of providing information on the following operation contingencies:

- unauthorized access;
- passage delay for more than 30 sec.;
- one or both optical arm rotation sensors are out of order.

A special signal "Ready" is generated in each of the above cases.

5.11.2 In case of unauthorized access the "Ready" signal is formed as follows: at 8° arm rotation one of the optical sensors (Fig.12) responds and the output contacts "Ready" and "Common" get broken (the beginning of the signal). When the barrier arms reset to home position, the both optical sensors become passive and the output contacts "Ready" and "Common" get closed (the finish of the signal).

5.11.3 In case of delay of an authorized passage for more than 30 sec. the signal "Ready" is formed as follows: if within 30 seconds from the moment of passage commencing, which is determined by the arm rotation at no less than 8° (i.e. activation of one of the optical sensors), the reset of barrier arms to home position does not happen, the output contacts "Ready" and "Common" break (the beginning of the signal). When the barrier arms reset to home position, the both optical sensors become passive and the output contacts "Ready" and "Common" are closed (finish of the signal).

5.11.4 When one or both of the optical sensors become out of order, the output contacts "Ready" and "Common" get broken (the beginning of the signal "Ready"). After fault removal the closed status of the contacts "Ready" and "Common" is renewed.

6 MARKING AND PACKAGING

The turnstile has the marking on the turnstile housing in the form of a label located on the inner panel of the turnstile housing (to get access to the label unscrew the fixing bolt of the cover (2), located beneath the hub (3) and carefully lift up the cover with the LED indication display (2) by turning it in direction of the display).

The complete delivery set of the turnstile (Chapter 4) is packed in a transportation box, which keeps it undamaged during the transportation and storage.

Transportation box dimensions (L × W × H), cm..... 114×32×32

Transportation box weight (gross) no more than 43 kg

7 SAFETY REQUIREMENTS

7.1 Installation safety requirements

The installation should be carried out only by the qualified personnel after careful study of this *Manual*.



Warning!

- All the cables should be connected up when the power supply is switched off from the AC mains.
- Only serviceable tools should be used for installation.
- Observe general electrical safety rules when laying out the cables.
- Before the turnstile first power on make sure its installation and connection have been made accordingly.

7.2 Operation safety requirements

Observe general electrical Operation safety rules when operating the turnstile.



Do not use!

- Do not use the turnstile under conditions that do not comply with the requirements of Chapter 2 of this Manual.
- Do not use the turnstile at supply voltage that does not comply with the requirements of Chapter 3 of the Manual.

Safety requirements on the power supply units operation are shown in their certificates.

8 INSTALLATION INSTRUCTIONS

8.1 Installation details



Caution!

Follow the safety requirements during the installation (see clause 7.1)

Correct turnstile installation provides its functionality and lifetime. Please carefully study and follow the installation instructions.



Caution!

The manufacturer shall not be liable for any damage caused as the result of improper installation and declines any claims arising thereof in case if the installation is not done in compliance with the instructions provided in this *Manual*.

It is recommended:

- to mount the turnstile on steady and level concrete (grade 400 or higher), stone or similar foundations at least 150 mm thick;
- to level the foundation so that the anchoring points of the turnstile lie in the same plane;
- to apply reinforcing elements (400×400×300mm) for installation on less steady foundation (frame foundation, for example);
- to mark the mounting holes according to Fig. 10;
- to control the vertical position of the turnstile during installation;
- to arrange additional emergency exit;
- when creating the passage area through the turnstile take into account that the resetting device operates as follows:
 - at the barrier arm turning at the angle of more than 60° the reset is effected in the direction of movement and the turn of barrier arm to counter direction is not possible (blocking of return passage) ;
 - at the barrier arm turning at the angle less than 60° the reset is effected in the counter to the movement direction (reset to home position).



Note:

The angle gradient, at which the barrier arm reset commences, may vary in the range of $\pm 5^\circ$.

To ensure accurate passage tracking, when the turnstile is operated from an ACS, it is recommended to create the passage area in such a way that the barrier arms should turn in the direction of movement at the angle no less than 70° (Fig. 9).

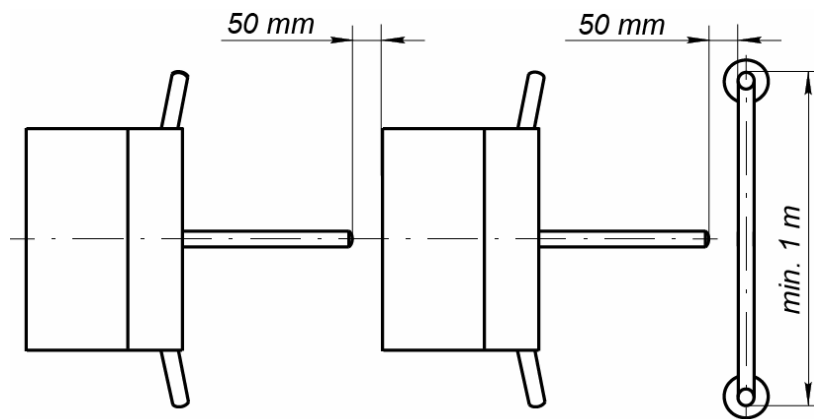

Figure 9. Site preparation. Recommendations

8.2 Installation tools

- 1.2÷1.5 kW hammer drill;
- Ø16 mm hard-alloyed drill bits;
- Floor chaser for electric raceway;
- Flat slot screwdriver No.2;
- Cross-head screwdriver;
- Horn-type and socket wrenches: S17, S13 and S10;
- Set square 90°;
- Plumb line and level;
- Measuring tape (2 m);
- Hard wire 1.5 m long for cable pulling
- Slide caliper.



Note:

It is allowed to use other testing equipment and measuring tools provided the equipment in use ensures the required parameters and measurement accuracy.

8.3 Length of cables

The maximum allowed length of the RC panel / WRC / ACS controller cable is no more than 50 m.

The maximum allowed length of the turnstile power cable depends on the cable cross-section and should be:

- for cable with 1.5mm² cross-section (AWG 15) max. 10 m;
- for cable with 2.5mm² cross-section (AWG 13) max. 15 m

When selecting the cable cross-section please consider the voltage loss on the cable at maximal load current 6 A for compliance with Chapter 3 (turnstile operating voltage).

8.4 Installation procedure

The following installation procedure complies with given installation recommendations (see clause 8.1).

1. Unpack the turnstile; check the completeness as per Chapter 3 of the Certificate.
2. Make the holes for anchor bolt (13) sleeves for the turnstile housing installation (Fig. 10). If you lay out cables under the floor surface, make an electric raceway to the cables laying zone of the turnstile housing (option 1 or 2 in Fig. 10)



Note:

Material, cross-section, measure, variant of cable laying (external, sunken, combined), placement on the entrance point and other cable duct parameters are specified by the Customer according to entrance point configuration, equipment disposition and other exploitation factors.

3. Insert sleeves for anchor bolts into the holes so that they do not stick out above the floor surface. Set up the housing and fix it with the M10 bolts. Fix the housing after laying the cables in the electric raceway and inside the turnstile housing.
4. Set in a working position the hab with barrier arms and secure it fastening bolts.

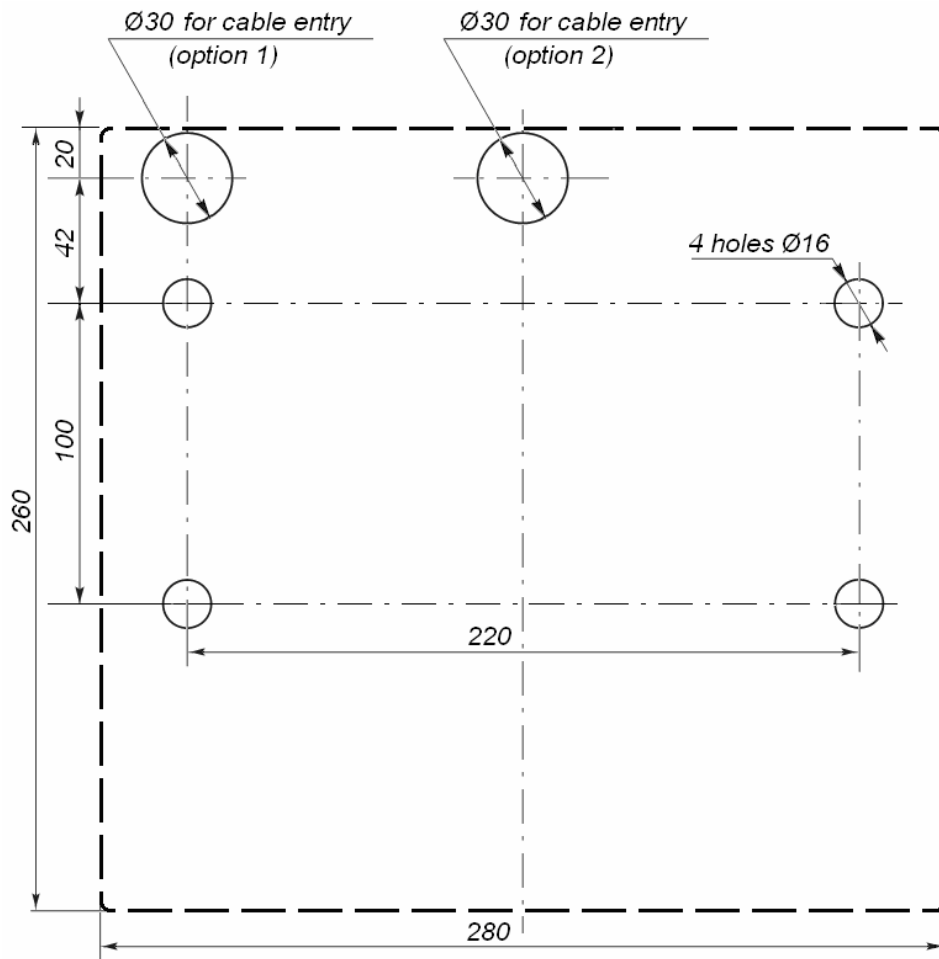

Figure 10. Floor anchor position and cable entries for housing installation (turnstile housing is dotted)

5. Remove the cover with LED indication display (2) in the following way:
 - unscrew the central bolt of the cover with LED indication display (2), located beneath the hub (3);
 - pull the bolt out of the turnstile housing hole;
 - remove the cover with LED indication display (2) by lifting the cover by its rear edge in the LED indication display direction and taking it out of the hooks;
 - carefully disconnect the indication board cable header from the CLB X1 connector and place the cover with light display (2) on the level steady surface.

6. Install the hub (3) and the barrier arms (5) in the following order:
 - Insert the hub into a corresponding mounting face on the turnstile mechanism shaft.



Caution!

For proper hub installation before the final tightening of the bolts, barrier arm is to be shifted into a horizontal position and a 90° degree angle in the horizontal between the barrier arm and the turnstile housing is to be set with a set square.

- Fix the hub with hub fastening bolts (4), inserting a split washer under each bolt head. Bolts' tightening is to provide solid hub fixation regarding the turnstile mechanism shaft (without gaps and mismatches).

7. Connect the power cable (8) from the turnstile power supply (7) to the CLB "XT3" connector block. Connect the RC panel (11) cable (12) to the CLB "XT1.L" connector block. Connect all the other devices cables to the corresponding CLB connector blocks. (See Fig. 4 and 11).

8. Check serviceability and accuracy of all the electrical connections.
9. Fasten all the cables in two points to the hole in the turnstile housing horizontal plane, using hook and loop cable ties.
10. Connect the indication board cable header to the control mechanism connector and mount the cover with LED indication display (2) back into its place in the reverse order. When the cover with LED indication display (2) mounting is carried out correctly it does not need much effort. Fasten the cover with a bolt.
11. Run a test switch on of the turnstile as specified in Chapter 9.
12. Check operation of the intrusion detector and siren (if included in the delivery set) by the way described below.
13. After the power-up wait until the moment of the test indicator (inside the intrusion detector) going off (from 10 to 50 sec), the turnstile should be in the "Always locked" mode (at the pulse control mode) or in the "Both directions closed" (at the potential control mode)). Put your hand before the intrusion detector. The continuous signal will sound when the intrusion detector activates. To eliminate that sound signal press any button on the RC panel. The sound will stop without pressing the button in 5 ± 0.5 sec.
14. Set the mounted barrier arm into the run position. The arm should be fixed automatically.
15. Install the $\varnothing 30$ plugs (14).
16. Install $\varnothing 16$ plug (included in the standard delivery set) into the hole for a screw fastening the turnstile cover, located on the housing.
17. Once the installation has been completed, the turnstile is ready for operation.

Table 1. Connection layout description

Legend	Item	Quantity	Note
A1	Electromagnet	1	
A2*, A3*	Remote indicators	2	RI A, RI B
A4*	Remote indicator power supply	1	
A5*	Siren, 12V DC	1	
A6*	Turnstile power supply	1	12V, 6A
A7	CLB	1	CLB.140
A8	Indication module	1	
A9	Motor	1	
A10	Optical arm rotation sensors	1	
A11	RC panel	1	H6/4
A12*	Wireless remote control kit	1	MSRF-4
A13*	Access control system	1	
A14*	Emergency unblocking device ("Fire Alarm")	1	
A15*	Intrusion detector	1	CLIP-4
1	Indication cable TTR-07.658.00	1	
2	Wire jumper. Installed when the emergency unblocking device (A14) is not connected	1	Installed on default
3	Wire jumper. Installed when the intrusion detector (A15) is not connected	1	Installed on default

* Supplied on request

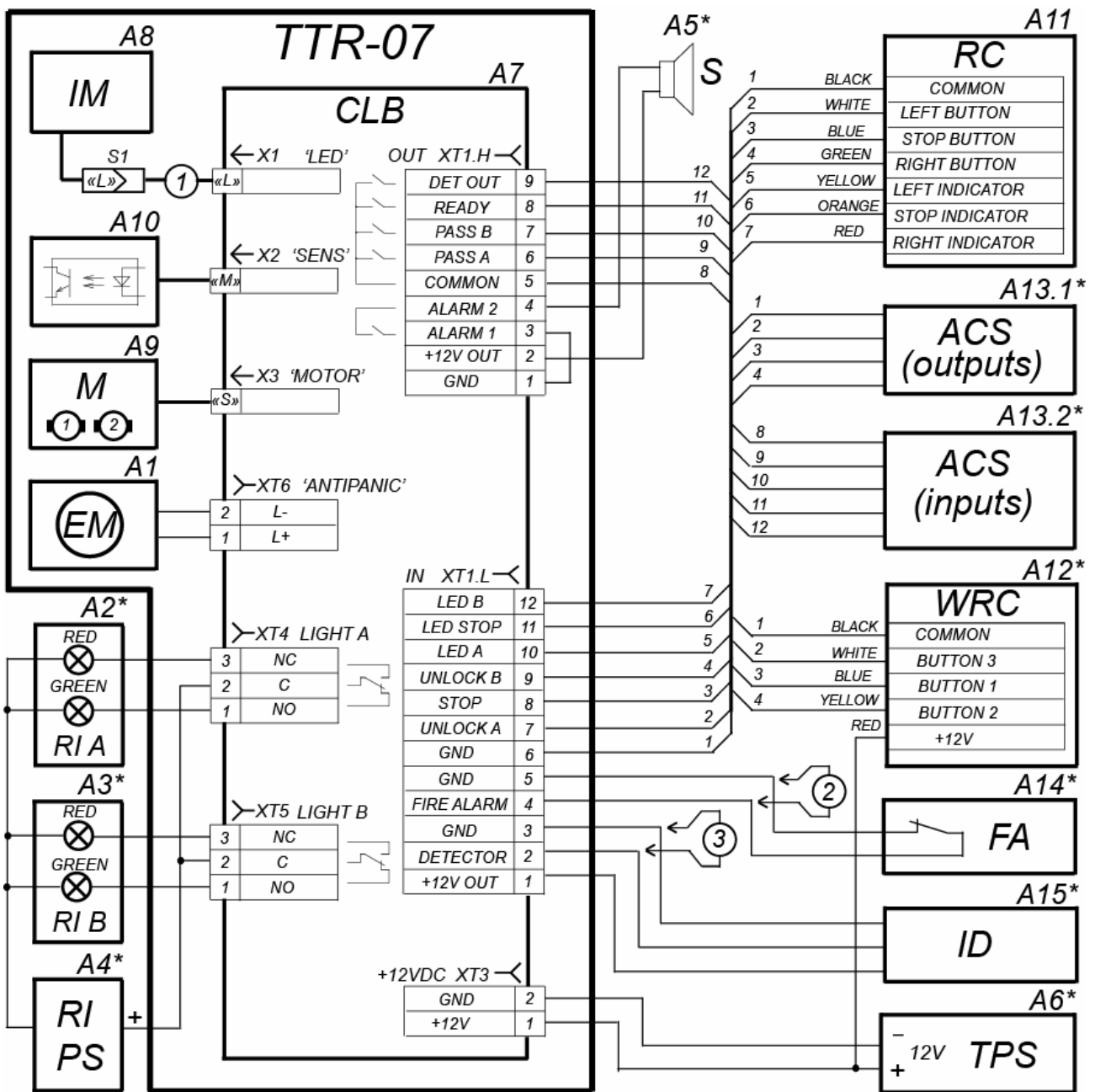

Figure 11. Connection layout (description is given in Table 1)

9 OPERATION INSTRUCTIONS



It is prohibited:

- To operate the turnstile without following the operation safety requirements (see Clause 7.2).
- To move through the turnstile passage area any objects with dimensions exceeding the width of the passageway.
- To jerk hit barrier arms, turnstile housing and light indication display so as to prevent their mechanical deformation.
- To disassemble and regulate turnstile components.
- To use abrasive or chemically active substances for cleaning for cleaning of the turnstile external surfaces.

9.1 Power- up

Check the accuracy of all the connections and the power supply cable operability (see Clause 8.4).

Connect the AC power cable (6) of the turnstile power supply (7) to the AC outlet with the voltage and frequency rating according to the certificate for power supply.

Switch on the turnstile power supply (7). At the same time the “Red cross” pictogram on the LED indication display of the turnstile housing and the indicator above the STOP button on the RC panel (11) light up. Set the mounted barrier arm into the run position. The arm should be fixed automatically.

9.2 Operating modes of the turnstile in pulse control mode

See Table 2 for the operating modes set from the RC PANEL and for the corresponding indication. Please note the following:

- Setting the operating modes for each direction is independent, i.e. setting the operating mode for one direction does not change the operating mode set earlier for the opposite one;
- The “Single passage in the set direction” mode can be changed to the “Always free” mode for the same direction, or to the “Always locked” mode;
- The “Free passage in the set direction” mode can be changed to the “Always locked” mode only.

At the turnstile power supply switching-on the reset state of the turnstile is “Closed”.

In the “Single passage in the set direction” mode the turnstile will close automatically after a person’s passage in the set direction. The turnstile will also close automatically, if the passage is not made within 5 sec. In the “Bi-directional single passage” mode after the passage in one direction the countdown of the passage waiting time (5 sec.) for the opposite direction is recommenced.



Note:

Pressing the button on the RC panel corresponds to the low-level signal supply to the contacts (“Unlock A”, “Unlock B” and “Stop”) of the “XT1.L” connector block relatively to the contact “GND”.

Table 2. Pulse control mode (the jumper is set on the J1 connector)

№	The turnstile operating modes	Actions to do	Indication on the RC panel	Indication on the LED display	Turnstile status
1	Always locked (Locked for entry and exit)	Press the STOP button on the RC panel	The red indicator above the STOP button is on	The “Red cross” pictogram is on	The turnstile is locked
2	Single passage in the set direction (open for passage of one person in the chosen direction)	Press the button on the RC panel corresponding to the chosen passage direction	The green indicator above the button of the chosen passage direction is on	The “Green arrow” pictogram, showing the passage direction is on	When the passage is completed, the turnstile is locked
3	Bi-directional single passage (open in both directions for ‘one-by-one’ passage)	Press both the left and right side buttons on the RC panel simultaneously	The two green indicators (left and right) are on	The two “Green arrow” pictograms (left and right) are on	The turnstile is locked in the direction of completed passage
4	Free passage in the set direction (open for free passage in the chosen direction)	Press the STOP button and the button corresponding to the chosen passage direction simultaneously	The green indicator above the button of the chosen passage direction is on	The “Green arrow” pictogram, showing the passage direction is on	Turnstile remains open in the set direction
5	Free passage in the set direction and single passage in the opposite direction (open for free passage in the chosen direction and for passage of one person in the opposite direction)	Carry out actions stated in Chapters 2 and 4 of the present table in any order	The two green indicators (left and right) are on	The two “Green arrow” pictograms (left and right) are on	After the passage in the free passage direction the turnstile remains open in both directions. After the passage in the single passage direction the turnstile remains open in the free passage direction but it is gets locked in the single passage direction
6	Always free (open for entry and exit)	Press all the 3 buttons on the RC panel simultaneously	The two green indicators (left and right) are on	The two “Green arrow” pictograms (left and right) are on	The turnstile remains open

9.3 Operating modes of the turnstile in potential control mode

See Table 3 for the operating modes set from the RC panel. Setting the operating modes for each direction is independent, i.e. setting the operating mode for one direction does not change the operating mode set earlier for the opposite one.

Table 3. Potential control mode (the jumper is taken off from the J1 connector)

No	The turnstile operating modes	Levels on the contacts should be provided	Indication on the RC panel	Indication on the LED display	Turnstile status
1	Both directions are locked (the turnstile is locked both for entry and exit)	The high level — on contacts “Unlock A” and “Unlock B” or low level — on the contact Stop	The red indicator above the STOP button is on	The “Red cross” pictogram is on	The turnstile is locked
2	One of the passage directions is open (the turnstile is open for passage in the set direction)	The low level — on the contact corresponding to the passage direction, the high levels — on the other contacts	The green indicator above the button of the chosen passage direction is on	The “Green arrow” pictogram, showing the passage direction is on	If by the moment of passage through the turnstile the low level is present on the contact, corresponding to the set passage direction, the turnstile remains open in the set direction
3	Both passage directions are open (the turnstile is open for passage in both directions)	The low levels — are on the contacts corresponding to the both directions, the high level — on the contact Stop	The two green indicators (left and right) are on	The two “Green arrow” pictograms (left and right) are on	If by the moment of passage through the turnstile the low level is present on the contact, corresponding to the set passage direction, the turnstile remains open in the set direction



For the ACS outputs note the following:

High level — contacts of the output relay are broken or the output transistor is closed

Low level — contacts of the output relay are closed or the output transistor is open.

9.4 Actions in emergency

For urgent evacuation of people from business facilities in case of fire, natural calamities and other emergencies, the additional emergency exit should be provided. Such emergency exit can be the automatic anti-panic rotary section PERCo-BH02.

The additional emergency exit can be provided by the turnstile passage area. Construction of the turnstile enables immediate clear of passage way without use of any special keys or tools. By putting the *Fire Alarm* signal to turnstile logic board the barrier arm automatically falls down allowing the free exit (see Clause 5.10). The arm also drops down automatically at a power supply loss.

9.5 Troubleshooting

Possible faults, which can be cleared by the users themselves, are listed in Table 4.

Table 4. Possible faults and remedy

Fault	Possible cause	Remedy
At the power-up the turnstile doesn't work, and there is no light indication on the turnstile housing and the RC panel	No supply voltage to the CLB	Switch off the turnstile power supply from the AC mains, open the turnstile housing cover, and remove the outer panel. Check the power cable serviceability and reliability of its connection to the CLB "XT3" connector block
The turnstile is not controlled in one of the directions, and there is light indication on the turnstile housing and on the RC panel	The CLB does not receive a control signal from this direction	Switch off the turnstile power supply from the AC mains, open the turnstile housing cover, and remove the outer panel. Check the RC panel / WRC kit / ACS controller cable serviceability and reliability of its connection to the CLB "XT1.L" and "XT1.H" connector blocks

All other faults shall be cleared by the Manufacturer or his representatives only.

10 MAINTENANCE

The turnstile housing maintenance is required once a year or in case of some technical failures. The maintenance should be carried out by qualified mechanic only.



Note:

Prior to the turnstile maintenance works disconnect the turnstile power supply from the AC mains.

Maintenance is carried out in the following order:

1. Remove the cover with LED indication display (2) from the turnstile housing.
2. Check visually the resetting device (pusher, springs and roller), the arm rotation sensors and the damper (Fig. 12).
3. Remove dust from the arm rotation sensor disc, located in the spacing of the arm rotation optical sensors, with alcohol-gasoline blend applied with a cloth. Avoid the ingress of dust on the operational spacing of the both arm rotation optical sensors.
4. Lubricate the friction units of the resetting device with the machine oil (see Fig. 12):
 - a. resetting mechanism pusher lever;
 - b. stop spring fastening axis;
 - c. stopper rotation axis.



Note:

Avoid the ingress of lubricant on the arm rotation sensor disc and the roller surfaces.

5. Check the reliability of the cable connections to the CLB connector blocks and if necessary tighten the cable fixing screws.
6. Connect the cable header of the indication board to the control mechanism connector and mount the cover with LED display (2) back into its place in the reverse order to the dismantling. When the cover mounting is carried out correctly it does not need much effort.
7. Check the reliability of the barrier arm (5) fastening
8. Check the reliability of hub fastening bolts (4).
9. Check the reliability of electromechanical barrier arm unblocking device by turnstile power on / off. If necessary lubricate the hinged connections to the hub (3).
10. Check the reliability of the turnstile housing fastening to the floor and if necessary, tighten the anchor bolts (13). To do that:
 - remove plastic plugs (14) out of the holes in the turnstile housing (1) base;
 - tighten the anchor bolts (13);
 - put the plastic plugs (14) into their places.

In case of any defects revealed during visual check please apply to the PERCo Technical Support Department (the PERCo TSD).

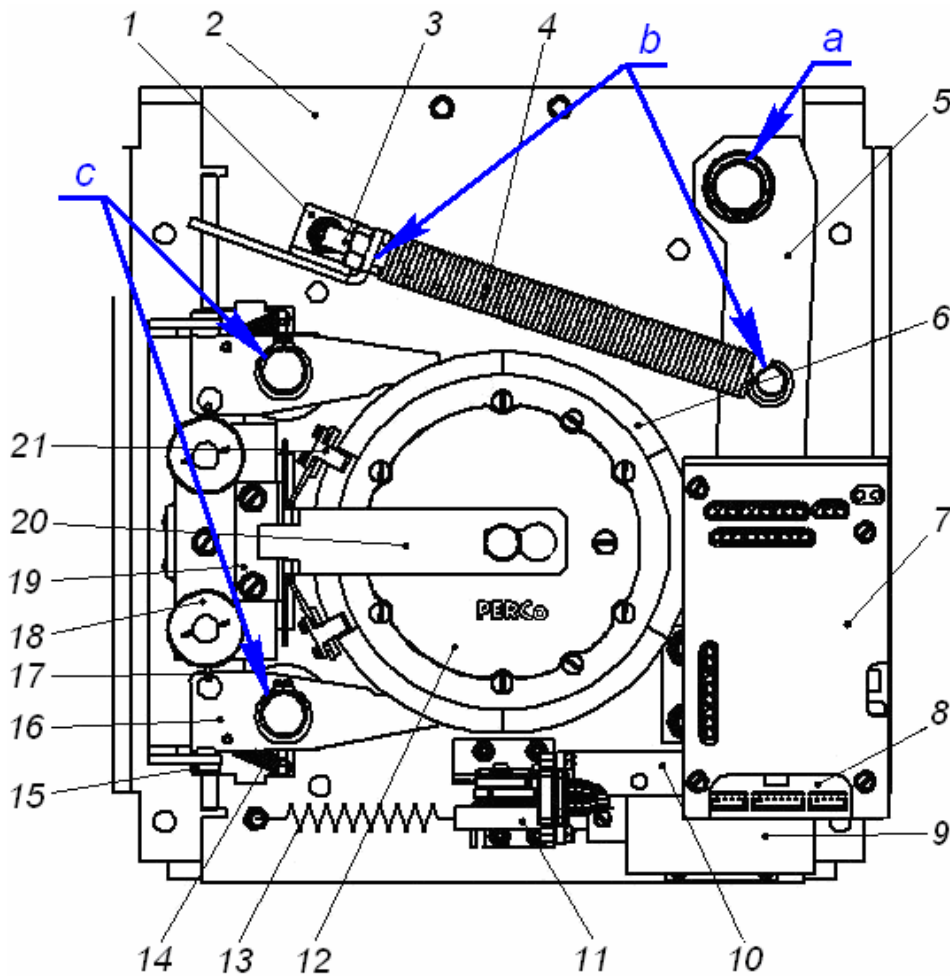

**Figure 12. Location of the interior components of the turnstile housing
(a, b, c – lubrication points)**

- 1 – stop spring bracket; 2 – mechanism base; 3 – stop spring pulling pin; 4 – stop spring;
 5 – resetting mechanism pusher lever; 6 – arm rotation sensor disk;
 7 – CLB protection glass; 8 – CLB; 9 – electromagnet; 10 – CLB bracket;
 11 – barrier arm drop mechanism; 12 – damper; 13 – barrier arm drop mechanism spring;
 14 – stopper spring; 15 – stopper absorber; 16 – resetting mechanism stopper;
 17 – winch; 18 – stopper unit motor; 19 – bracket; 20 – damper holder;
 21 – optical arm rotation sensor.

11 TRANSPORTATION AND STORAGE

The turnstile in the original package should be transported in closed freight containers or in other closed type cargo transport units. During storage and transportation the boxes can be stacked no more than 4 layers high.

The storage of the turnstile is allowed indoors at ambient temperature from -40°C to $+45^{\circ}\text{C}$ and at relative air humidity up to 98% at $+25^{\circ}\text{C}$. The environment should be free of acid and alkali vapours and gases that cause corrosion.

After transportation or storage at temperatures below zero or at high air humidity, prior to the installation the turnstile must be kept in the original package for no less than 24 hours indoors at room temperature.

APPENDIX A Control signal algorithm in pulse control mode

The command is a signal active front (signal transfer from the high level to the low level) at any of the contacts at presence of the corresponding signal levels at the other contacts. The following commands can be formed by sending a low-level signal to the contacts "Unlock A", "Stop" and "Unlock B" of the "XT1.L" connector block relatively to the contact "GND":

Always locked (locked for entry and exit)

Active front is at the contact "Stop" while there is a high level at the contacts "Unlock A" and "Unlock B". Both passage directions are locked at this command.

Single passage in the direction A (open for passage of one person in the direction A)

Active front is at the contact "Unlock A" while there is a high level at the contacts "Stop" and "Unlock B".

At this command the passage direction A opens either for 5 sec. or until the passage has been made in this direction or until the command "Always locked", and the status of the passage direction B does not change at that. The command is ignored if at the moment of its receipt the status of the passage direction A is "Always free".

Single passage in the direction B (open for passage of one person in the direction B)

Active front is at the contact "Unlock B" while there is a high level at the contacts "Stop" and "Unlock A".

At this command the passage direction B opens either for 5 sec. or until the passage has been effected in this direction or until the command "Always locked", and the status of the passage direction A does not change. The command is ignored if at the moment of its receipt the status of passage direction B is "Always free".

Bi-directional single passage (open for one passage in each direction)

Active front is at the contact "Unlock A" while there is a low level at the contact "Unlock B" and a high level at the contact "Stop",

or active front is at the contact "Unlock B" while there is a low level at the contact "Unlock A" and a high level at the contact "Stop".

At this command the both passage directions open either for 5 sec. each or until the command "Always locked" is received. The command is ignored for the passage direction, which status at the moment of its receipt is "Always free".

Free passage in the direction A (open for free passage in the direction A)

Active front is at the contact "Unlock A" while there is a low level at the contact "Stop" and a high level at the contact "Unlock B",

or active front is at the contact "Stop" while there is a low level at the contact "Unlock A" and a high level at the contact "Unlock B".

At this command the passage direction A opens until the command "Always locked" is received; the status of the passage direction B does not change at that.

Free passage in the direction B (open for free passage in the direction B)

Active front is at the contact "Unlock B" while there is a low level at the contact "Stop" and a high level at the contact "Unlock A",

or active front is at the contact “Stop” while there is a low level at the contact “Unlock B” and a high level at contact “Unlock A”.

At this command the passage direction B opens until the command “Always locked” is received; the status of the passage direction A does not change at that.

Free passage (open for free passage in both directions)

Active front is at the contact “Unlock A” while there is a low level at the contacts “Unlock B” and “Stop”,

or active front is at the contact “Unlock B” while there is a low level at the contacts “Unlock A” and “Stop”,

or active front is at the contact “Stop” while there is a low level at the contacts “Unlock A” and “Unlock B”.

The both directions open at this command until the command “Always locked” is received.



Note:

For the RC panel:

- active front – pressing of the relevant button on the RC panel;
- low level – the relevant button on the RC panel has been pressed;
- high level – the relevant button on the RC panel is not pressed.

APPENDIX B Control signal algorithm in potential control mode

Both directions are locked (locked for entry and exit)

There is a high level at the contacts “Unlock A” and “Unlock B”, or a low level at the contact “Stop”. The both passage directions lock at this command.

The direction A is open (open for passage in the direction A)

There is a low level at the contact “Unlock A” while a high level is present at the contacts “Stop” and “Unlock B”.

At this command the direction A opens till the low-level signal removal from the contact A or until the command “Both directions locked” is received. The status of the direction B does not change at that.

The direction B is open (open for passage in the direction B)

There is a low level at the contact “Unlock B” while there is a high level at the contacts “Stop” and “Unlock A”.

At this command the direction B opens till the low-level signal removal from the contact B or until the command “Both directions locked” is received. The status of the direction A does not change at that.

Both directions are open (open for entry and exit)

There is a low level at the contacts “Unlock A” and “Unlock B” while there is a high level at the contact “Stop”.

The both directions open at this command till the low-level signal removal from one of the contacts A (B) or until the command “Both directions locked” is received.



Note for ACS controller outputs:

low level – either contacts of the output relay are closed or the output transistor is open;

high level – either contacts of the output relay are broken or the output transistor is closed.

PERCo

P.O. Box 87,
Saint Petersburg, 194295,
Russia

Tel: +7 812 321 61 72

Fax: +7 812 292 36 08

E-mail: export@perco.ru
support@perco.ru

www.perco.com



www.perco.com
export@perco.ru